



# RENAULT UK CLIO CUP JUNIOR REGULATIONS 2018

**(PUBLISHED COPY V4 – 31<sup>st</sup> January 2018)**



# CONTENTS

	PAGE		PAGE
<b>1. SPORTING REGULATIONS</b>	<b>5</b>	<b>5. TECHNICAL REGULATIONS</b>	<b>15</b>
1.1. Title and Jurisdiction	5	5.1. Introduction	15
1.2. Officials	5	5.2. General Description	15
1.3. Competitor Eligibility	5	5.3. Safety Requirements	16
1.4. Registration	6	5.4. General Technical Requirements and Exceptions	17
1.5. Championship Rounds	6	5.5. Chassis	18
1.6. Points Scoring	6	5.6. Bodywork & Measurements	19
1.7. Awards	7	5.7. Main Dimensions	19
1.8. Paddock Regulations	7	5.8. Engine	19
1.9. Passes	7	5.9. Suspension	20
1.10. Fuel	7	5.10. Transmission	21
1.11. Tyres	7	5.11. Electrics	21
<b>2. JUDICIAL PROCEDURES</b>	<b>8</b>	5.12. Brakes	21
<b>3. CHAMPIONSHIP EVENTS/ RACE PROCEDURES</b>	<b>8</b>	5.13. Wheels/Steering	22
3.1. Entries	8	5.14. Tyres	22
3.2. Briefings	8	5.15. Weight	23
3.3. Scrutineering Protocol	8	5.16. Fuel	23
3.4. Qualifying	9	5.17. Silencing and Exhaust	24
3.5. Qualification	10	5.18. Lubricant Testing	24
3.6. Races	10	<b>6. COMMERCIAL REGULATIONS</b>	<b>25</b>
3.7. Start Procedure	10	6.1. Championship Contacts	25
3.8. Start Delayed/Abort Procedure	11	6.2. Penalties	26
3.9. Safety Car	11	6.3. Passes	26
3.10. Stopping a Race	11	6.4. Paddock Regulations	26
3.11. Re-Scrutiny/Competitor Availability	12	6.5. Timetable Regulations	27
3.12. Pits & Pit Lane Safety	12	6.6. Radios	27
3.13. Race Finishes	12	6.7. Advertising	27
3.14. Results	13	6.8. Testing	28
3.15. General Regulations	13	6.9. Publicity	28
<b>4. CHAMPIONSHIP PENALTIES</b>	<b>13</b>	6.10. Television	29
4.1. Infringements of Technical Regulations	13	6.11. Championship Cameras	29
4.2. Infringements of non-Technical MSA Regulations and the Sporting Regulations issued for the Championship	14	6.12. Miscellaneous	29
		<b>Appendix A – Suit Decal Plan</b>	<b>30</b>
		<b>Appendix B – Car Decal Plan</b>	<b>31</b>
		<b>Appendix C – Race ‘n’ Respect Principles</b>	<b>32</b>



## 1. SPORTING REGULATIONS - GENERAL

### 1.1. Title and Jurisdiction

The 2018 Renault UK Clio Cup Junior is registered and organised by the British Automobile Racing Club (BARC) and administered by Renault UK Ltd in accordance with the General Regulations of the Royal Automobile Club Motor Sports Association (MSA) incorporating the provisions of the International Sporting Code of the FIA and these Championship Regulations.

MSA Permit Number: CH2018/RXD004  
Race Status: National B  
MSA Championship Grade: C

The Championship Organisers reserve the right to amend or vary the Sporting Regulations in accordance with MSA Regulation D11.1 at any time before or during the Championship and further issue additional statements concerning the Regulations from time to time, subject to MSA approval, and all such statements will be issued in a Championship Bulletin to the MSA and to all registered Competitors by posting on the official Championship website [www.renaultsport.co.uk/internalnews/](http://www.renaultsport.co.uk/internalnews/) or delivery to the Competitor by hand. All Competitors, team members, manufacturers, and persons associated with any of the above agree to be bound by the Regulations including any amendments, variations or statements relating thereto.

The Championship Organisers reserve the right to cancel or postpone the entire event subject to the agreement of the MSA, and as far as the calendar is concerned, claim for damages or compensation or claim to performance are in this case excluded.

### 1.2. Officials

1.2.1.	Championship Manager/Co-ordinator:	Will Fewkes	Renault UK
1.2.2.	Championship Eligibility / Safety Scrutineer:	Keith Auld/Rob Mason	BARC
1.2.3.	Championship Stewards:	Jeremy Townsend	Renault UK
		Dennis Carter	BARC
		Dale Wells	BARC
		Pat Blakeney	BARC

Any three of the Championship Stewards may sit to make a decision. In accordance with (G) 2.7, Championship Stewards may only adjudicate on any disputes, irregularities or appeals arising from the approved Championship regulations. Under (G) 2.7.1, Championship Stewards are also empowered to consider any request from the Championship co-ordinator to penalise any Competitor for any breach of Championship regulations after holding a formal hearing to impose a penalty in accordance with C.2.1.1 (subject to the rights of appeal provided for in Section C). Under (W) 2.2.1, the Championship Stewards can only adjudicate upon any disputes, irregularities or appeals arising from the approved Championship Regulations. They are also empowered to consider any request from the Championship Co-ordinator to penalise any Competitor for breach of Championship Regulations and after holding a formal hearing, to impose a penalty in accordance with C.2.1, subject to the rights of appeal to the MSC provided in Section C.

1.2.4.	Clerk of the Course:	Trevor Williams	BARC
1.2.5.	Championship Promoter:	Renault UK	

### 1.3. Competitor Eligibility

1.3.1. Drivers must be fully paid-up, valid membership card-holding racing members of the BARC, with the sole exception of any Driver nominated by the Championship Manager to drive car '0', be registered by an Entrant for the Championship and be in possession of a current MSA Competition (Racing) License National 'B' endorsed 'Junior Formulae only' and medical.

1.3.1.1. Entrants must be fully paid up valid membership card holding members of the BARC and be in possession of a valid Entrant's Licence issued by the MSA (Entrant's Licence). This must be presented to the Championship Manager at their first Event. Where the Entrant is the Driver an Entrant's Licence is not required.

1.3.2. All necessary documentation must be presented for checking at all rounds when signing-on. However each Drivers Competition Racing Licence being a "Junior" licence will be held by the Organisers for the duration of the Championship.

1.3.2.1. The minimum age for a Driver is 14 (Fourteen) years old. A Driver must attain the age of 14 (fourteen) before a Championship Registration can be accepted. A Driver may not take part in any Championship official test, free practice session, qualifying session or race in the Championship until attaining the age of 14 (Fourteen) years. Drivers who reach the age of 17 during the racing season (1<sup>st</sup>, January – 31<sup>st</sup>, December 2018) may continue to take part in all rounds of the Championship for the remainder of the season.

1.3.3. Only those cars complying with the Current Technical Regulations for the Championship and/or any amendments to the Technical Regulations issued from time to time by way of an official Championship Bulletin, in accordance with MSA Regulation D11.1 will be allowed to compete in any round of the Championship.

- 1.3.4 Competitors must ensure that their cars comply with the conditions of eligibility and safety throughout qualifying and racing.
- 1.3.5 At any time during an Event, the Championship Clerk of the Course can require a Driver to have a medical examination.

**1.4. Registration**

1.4.1. All Entrants must register their Drivers for the Championship by completing the Championship Registration Form in full and returning it, together with the Registration Fee, to the Championship Manager prior to the closing date for registrations on the last day in **February 2018**. Registrations are accepted on a 'first come first served basis' up to a maximum of 36 (thirty-six) prior to the first Event. The Organisers reserve the right to accept registrations after this date and any such acceptance of registration and the terms thereof is at the discretion of the Organisers.

1.4.2. The Championship Registration Fee is **£5,995 (plus VAT)** at the applicable rate. Total payable **£7,194** for any participant that signs up for a full campaign.

**1.4.3. Numbers and Championship Decals**

Each registered Driver will be allocated a unique permanent competition number for the season. Registration numbers will be the permanent competition numbers for the Championship. These numbers will be allocated by the Championship Manager and recorded and will remain with the Driver for the duration of the Championship. These numbers will be issued strictly on receipt of a fully completed registration form and the fee.

- 1.4.3.1. The only authorised numbers are those allocated by the Championship Manager.
- 1.4.3.2. The number decals will be of a special Championship standard/style and design and at all times will be subject to acceptance by the Chief Timekeeper and Chief Observer at Events.
- 1.4.3.3. Each car must display its allocated competition number in accordance with **Appendix B** during Championship official test days, free practice, qualifying sessions and races.
- 1.4.3.4. Following completion of registration the Championship Organisers will supply the number panels and a complete sets of mandatory decals including the Driver name decals.
- 1.4.3.6. The positions of all mandatory decals are shown in **Appendix B**.

**1.4.4. Medical**

1.4.4.1. A Medical Information Sheet must be completed and returned to the Medical Adviser via the Championship Organisers, at least 7 (seven) days prior to the first Event or the Championship official test day in which a Driver intends to compete.

1.4.4.2. Drivers must notify the Medical Adviser if:

- (i) the Driver is involved in any serious accident at any Championship official test day, Event or otherwise at any venue.
- (ii) there is a significant change in the general physical or mental condition of the Driver.
- (iii) the Driver is hospitalised for any reason.
- (iv) drugs are taken for any medical conditions that have not been previously notified.

**1.5. Championship Rounds**

1.5.1. The Current Renault UK Clio Cup Junior Championship will be contested over **6 (six)** Events, with 2 (two) rounds at each Event as follows:

Date	Circuit	Organising Club
24 <sup>th</sup> /25 <sup>th</sup> March	Silverstone	BARC
14/15 <sup>th</sup> April	Rockingham	BARC
20 <sup>th</sup> /21 <sup>st</sup> July	Donington Park	BARC
8 <sup>th</sup> /9 <sup>th</sup> September	Snetterton	BARC
22 <sup>nd</sup> /23 <sup>rd</sup> September	Croft	BARC
3 <sup>rd</sup> /4 <sup>th</sup> November	Brands Hatch	BARC

1.5.2. In accordance with MSA Regulation **D11.1** the Championship Organisers reserve the right to amend the composition of the Championship rounds at any stage of the season and will give as much notice as possible to all Competitors through the issuing of a Championship Newsletter to all registered Competitors. However, the number of Championship rounds will not be increased.

**1.6. Points Scoring**

1.6.1. **1<sup>st</sup>: 25 points 2<sup>nd</sup>: 22 points 3<sup>rd</sup>: 20 points 4<sup>th</sup>: 18 points 5<sup>th</sup>: 16 points 6<sup>th</sup>:13 points 7<sup>th</sup>: 10 points 8<sup>th</sup>: 8 points 9<sup>th</sup>: 7 points 10<sup>th</sup>: 6 points 11<sup>th</sup>: 5 points 12<sup>th</sup>: 4 points 13<sup>th</sup>: 3 points 14<sup>th</sup>: 2 points 15<sup>th</sup>: 1 points**

2 (two) points will be awarded to the Driver(s) setting the fastest lap in each round.

- 1.6.2.** Drivers shall count their results from the total number of races run less one race. Each driver's single dropped score cannot be taken from the final two rounds of the championship. Competitors who are excluded from any race must count that excluded race within their total score.
- 1.6.3.** Ties shall be resolved as follows:
- (i)** by considering the number of first places of the Drivers concerned. If this does not resolve the situation then:
  - (ii)** by considering the number of second places, and so on, of the Drivers concerned. Should a resolution still not be reached, the Championship result will be decided:
  - (iii)** by considering the result in the final round of the Championship of the Drivers concerned.
- 1.7. Awards**
- 1.7.1.** All awards are to be provided by Renault UK and paid to the Entrant by cheque or bank transfer.
- 1.7.2.** At each Championship round a trophy will be awarded to the first three finishers. Trophies are to be provided for podium presentation at the end of each round.
- 1.7.3.** End-of-Season Prize Fund:  
Champion: A Champion's trophy, a full registration to the 2019 Renault UK Clio Cup non-transferable within two year's will be awarded.
- 1.7.4.** Entrants' Trophy: Points will be awarded to the two highest placed cars from each team in each race (provided they are listed as a classified finisher in the final results) as per the format of Points Scoring for the Drivers' Championship, except the additional 2 (two) points for the fastest lap will not be awarded.  
A trophy will be awarded to the Entrant who has scored the most points in this Championship
- 1.7.5.** A voucher to the value of £155.00 will be awarded to a team at each round of the championship which may then be used in payment for fuel purchased through the official supplier.
- 1.7.6.** Any further awards will be announced by competitor bulletin during the championship season.
- 1.7.7.** The Drivers Champion is expected to attend the BARC Annual Awards Dinner and failure to do so may render them liable to lose all prizes.
- 1.7.8. Entertainment Tax Liability**  
In accordance with current government legislation, the Championship Organiser is legally obliged to withhold tax at the basic rate on all payments to non-UK resident sportsmen/women and account to HMRC using form FEU1, the quarterly return of payments made to non-resident entertainers and sportsmen/women.  
That is, those persons who do not have a normal permanent residence in the UK. The UK does not include the Isle of Man, Channel Islands or Eire. This means that, as the organiser, the Championship Organiser is required to deduct tax at the current rate applicable from any such payments they may make to non-UK residents.  
Under certain circumstances, it may be possible for competitors to enter into an agreement with the Inland Revenue to limit the tax withheld. Any application for such an arrangement must be made in writing and not later than 30 days before the payment is due.  
For further information contact:- HMRC Personal Tax International, Foreign Entertainers Unit, St John's House, Merton Road, Liverpool L75 1BB. Tel: 0151 472 6488 F 0151 472 6483
- 1.7.9** In the event of any provisional results or Championship standings being revised after any provisional presentations and such revisions affecting the distribution of any awards, the concerned must return such awards to the Championship Manager in good condition.
- 1.8. Paddock Regulations**
- 1.8.1.** Please refer to Regulation 6.4.
- 1.9. Passes**
- 1.9.1.** Please refer to Regulation 6.3.
- 1.10. Fuel**
- 1.10.1.** Please refer to the Technical Regulations for information regarding fuel.
- 1.11. Tyres**
- 1.11.1.** Please refer to the Technical Regulations for information regarding tyres.

## 2. JUDICIAL PROCEDURES

- 2.1 In accordance with Section C of the current MSA Yearbook and these Sporting Regulations.
- 2.1.1 By registering for the Championship all competitors, and their associates, commit to the MSA Race 'n' Respect campaign and agree to positively promote and demonstrate the Racing Code, which is appended to these regulations as Appendix C.
- 2.1.2 Where any reports of disrespectful conduct are judged to be well founded the Championship Organisers may issue warnings or require remedial actions and/or report the matter to the Championship Stewards who may impose appropriate penalties which can include loss of Championship points and/or race bans through to Championship Expulsion and referral to the MSA

## 3. CHAMPIONSHIP EVENTS/RACE PROCEDURES

### 3.1. Entries

- 3.1.1. The Championship Registration Form that includes the race Entry Form will be issued to all applicants by the Championship Organisers.
- 3.1.2. Entrants are responsible for sending in fully completed Registration Forms, signed by the competing Competitor and Parent/Guardian together with the registration fee to the Championship Manager prior to the closing date, the last day of February 2018. The Championship Organiser reserves the absolute right to accept registration/entries after that date.
- 3.1.3. Any withdrawal of entry or amendments to an entry must be notified to the Championship Manager in writing. If changes are made after publication of Entry Lists with Final Instructions, the Competitor concerned must apply for approval of acceptance by the Stewards of the Meeting before signing-on.
- 3.1.4. Entry for each round is included within the Registration Fee.
- 3.1.5. Please refer to Regulation 6.3.10 regarding refunds.
- 3.1.6. The Organisers may accept up to 20% more entries than specified on the Track Licence for each circuit and all accepted Competitors may participate in official Championship qualifying. Entries will be accepted up to the total number allowed to qualify.
- 3.1.7. The maximum number of starters permitted in each race will be in accordance with each specific Track Licence. The fastest Drivers will qualify for each race, subject to meeting the requirements of Regulation 3.5.1.
- 3.1.8. There is no provision for qualification races.
- 3.1.9. There will be no reserve entries. At circuits where the MSA Track Licence permits less cars to participate in qualifying than there are registered Drivers, entries will be selected by the Championship Organisers 4 (four) days prior to the commencement of the Event as follows:
  - First Priority: Championship points scorers.
  - Second Priority: Drivers who have competed in the most number of rounds.
  - Third Priority: Order of receipt of fully paid up and complete registration.
- 3.1.10. At circuits with a track licence of less than 36 (thirty-six) cars, any Drivers failing to qualify will be placed in order as reserves according to the position achieved during qualifying.

### 3.2. Briefings

- 3.2.1. Competitors will be informed in a Championship Newsletter of the time for the Drivers' Briefing at each event. Additional briefings may be called during an Event and, in this case, the Championship Manager or their appointed representative will inform all concerned of the time of the Briefing. Attendance at Briefings is mandatory and failure to attend may result in a fine.

### 3.3. Scrutineering Protocol

- 3.3.1. The Championship Organisers will appoint a permanent Championship Eligibility/Safety Scrutineer who, with his team, will be responsible for the scrutineering of the vehicles for the qualifying sessions and races of the Championship in accordance with Regulation 1.2.
- 3.3.2. For scrutineering, the Competitor must present the competing vehicle and mandatory Competitor safety equipment. The vehicle must be submitted as used in the Championship and must correspond to all applicable Technical Regulations and the appropriate Technical Manual in accordance with Regulation 5.1.
- 3.3.3. A completed Technical Passport and Seal and Component Identification Record Form for the vehicle must be correctly submitted in accordance with Regulation 3.3.12 and Regulation 3.3.13.
- 3.3.4. Following significant repair work, the vehicle should be presented to the Championship Eligibility/Safety Scrutineer or his appointed representative for inspection before taking part in any Championship official test day, free practice, qualifying session or race.



- 3.3.5.** Aside from the official Championship safety scrutineering, the vehicles may also be eligibility scrutineered during and after the Event. Vehicles will be selected at the sole discretion of the Championship Eligibility/Safety Scrutineer or his appointed representative. The Championship Eligibility/Safety Scrutineer and/or his appointed representative will make random checks in addition to scheduled scrutineering checks for vehicle eligibility throughout Events. Any infringement will be subject to a report to the Clerk of the Course.
- 3.3.6.** Competitors must comply with the directives of the Championship Eligibility/Safety Scrutineer and/or his appointed representative in respect of scrutineering and of re-scrutineering after the Event.
- 3.3.7.** After each qualifying session and race the vehicles must be presented directly for scrutineering. Any area deemed necessary by the Championship Eligibility/Safety Scrutineer and/or his appointed representative will be subject to Parc Fermé conditions with no exceptions. This will usually include the track from the Finish Line to the scrutineering area, the waiting area in front as well as the track from the scrutineering area to Parc Fermé but all areas may be used if necessary.
- 3.3.8.** Cars will be held in Parc Fermé for a minimum of 20 minutes after each qualifying session and race until released by the Championship Eligibility/Safety Scrutineer.
- 3.3.9.** At any time the Championship Organisers reserve the right to scrutineer any component or vehicle in the presence of the permanent Championship Eligibility/Safety Scrutineer and one other scrutineer at the workshop or at a service partner. An invited member of the team may also be present. Removal of components from the car may be required at the Event or at the workshop at the discretion of the Championship Eligibility/Safety Scrutineer. After thorough scrutineering of the parts, the result will be submitted to the Clerk of the Course.
- 3.3.10.** In the case of a breach of the Technical Regulations or a breach of the procedure surrounding the Technical Regulations, any costs associated with scrutineering and/or eligibility inspections (including, but not limited to transportation, checks, inspections, rebuilds, etc.) will be the sole responsibility of the Entrant.
- 3.3.11.** The assembly and dismantling of the vehicle(s) is solely the responsibility of the Entrant/s. Reimbursement of expenses for these measures may not be claimed. Exceptions to this may include appeal/protest according to MSA Yearbook section **C**.
- 3.3.12. Seal and Component Identification Form**
- 3.3.12.1.** All cars will be issued with Seal and Component Identification Record Forms. These will be used to record the details and location of all component sealing and identification marks.
- 3.3.12.2.** The form must be signed by the Competitor and the Championship Eligibility/Safety Scrutineer or his appointed representative and deposited in the Technical Support Vehicle.
- 3.3.12.3.** The Competitor of each car will be issued with the back copy of the form and will be responsible for its safekeeping.
- 3.3.12.4.** If required, the form must be available for inspection at pre-event scrutineering and should be a true reflection of the details.
- 3.3.12.5.** If the details or location of any component sealing or identification mark changes, a replacement form will be issued. The only person authorised to issue Seal and Component Identification Record forms is the Championship Eligibility/Safety Scrutineer or his appointed representative. Missing or incorrect forms will be the subject of a report to the Clerk of the Course.
- 3.3.13. Technical Passport**
- (i)** All cars are issued with a Technical Passport. This is used to record information relating to that car during the season. The Competitor is responsible for the safe keeping of the passport, which shall be presented with the car at pre-event scrutineering. No car is permitted to take part in an Event unless the Technical Passport is available for inspection at pre-event scrutineering and is a true reflection of the vehicle details.
- (ii)** The only person authorised to make changes to the details of the Technical Passport is the Championship Eligibility/Safety Scrutineer or his appointed representative. Missing Technical Passports will be the subject of a report to the Clerk of the Course.
- (iii)** It is mandatory to return the Technical Passport to the Eligibility/Safety Scrutineer at the end of the season.
- 3.4. Qualifying**
- 3.4.1.** At each Event the minimum scheduled qualifying session will be 1 (one) x 20 (Twenty) minutes. Qualification for the first Championship round of an Event will be based upon the fastest qualifying time recorded during the official Championship qualifying session. Qualification for the second Championship round of an Event will be based upon the second fastest qualifying time recorded during the official Championship qualifying session.
- 3.4.2.** During the course of any qualifying session, all competing cars must remain in the Pit Lane while not on the track. At no time will any competing car be allowed in the Pit Garages or Paddock areas until such time as the qualifying session has ended and the car cleared from any post-qualifying scrutineering checks and released from Parc Fermé, except with the express permission of the Clerk of the Course.
- 3.4.3.** Should the need arise to stop a qualifying session, red lights will be switched on at the Start/Finish Line and Red Flags will be displayed at the Start/Finish Line and waved at all Marshals' Signalling Posts around the circuit. This is the signal for all Drivers to cease driving at racing speed and proceed slowly, without overtaking and with the maximum caution, to the Pit Lane and be prepared to stop should the track be

blocked. The Clerk of the Course may request the Medical Advisor to proceed onto the circuit in the Medical Car, stopping if necessary at any incident.

**3.4.4.** After taking the Chequered Flag, Drivers are required to progressively and safely slow down, remain behind any Drivers ahead of them and proceed directly to the designated Parc Fermé area without stopping unless directed by an Official of the Meeting. Cars must remain in the designated Parc Fermé area until formally released by the Championship Eligibility/Safety Scrutineer.

**3.4.5.** Any stationary cars in the Pit Lane at the end of a qualifying session come under Parc Fermé conditions at the showing of the Chequered Flag and should be taken directly to the designated Parc Fermé area.

### **3.5. Qualification**

**3.5.1.** Each Driver should complete a minimum of 3 (three) qualifying laps in the car to be raced and in the correct session in order to qualify for selection and order of precedence in accordance with MSA Regulations unless through force majeure. The Clerk of the Course shall have the right to exclude any Driver whose qualifying times or driving are considered to be unsatisfactory – in accordance with MSA Regulation **Q4.5**.

In the case of force majeure, provided that a Driver has satisfactorily completed 3 (three) laps at an official Championship test day in that season and in a similar car at that circuit prior to the Event, it will not be necessary to complete 3 (three) laps of qualifying to qualify for the race.

**3.5.2.** Where, through force majeure, it is not possible to hold a qualifying session, the grid for that race will be formed according to the current Drivers' Championship point's standings. Where there is a tie on points, the Driver with the best result in the previous round will take priority.

### **3.6. Races**

**3.6.1.** 2 (two) Championship rounds, each covering a minimum time of 20 (twenty) minutes wherever possible, each preceded by 1 (one) Green Flag Lap led by the Championship Safety Car, will be held per Event.

**3.6.2.** At certain Events, it may only be possible to hold 1 (one) Championship race. In such cases, all other Championship Regulations will apply as normal.

**3.6.3.** Should any race be reduced in length at the discretion of the Clerk of the Course and/or Stewards of the Meeting, it will still count as a full points-scoring round.

### **3.7. Start Procedure**

**3.7.1.** When the signal is given, the cars will be released on to the circuit behind the official Championship Safety Car and led to the grid. Once the train of cars following the Safety Car has left the Assembly Area, the Assembly Area and Pit Lane Exit will be closed. During this lap the cars will keep in formation with no overtaking. The official Championship Safety Car will set the pace. No practice starts may be executed during the course of this lap. At the end of this lap the cars will take up their grid positions. Any car unable to join the train of cars following the Safety Car shall be held in the Pit Lane and may only exit the Pit Lane after the last car has passed the Pit Lane Exit on the Green Flag Lap, but shall only do so under the instruction of the Pit Lane Marshals. The car must then join the train at the back of the grid in front of any car with a time delay.

If a car is unable to re-join on the Green Flag Lap it shall be held in the Pit Lane and may only start the race after the last car to take the start has passed the Pit Lane Exit on the first racing lap, but shall only do so under the instruction of the Pit Lane Marshals.

**3.7.2.** The grid formation will be 2x2x2.

**3.7.3.** The Countdown Procedures/Audible Warnings sequence shall be:

2 (two) minutes to start of Green Flag Lap: Audible & Visible Warning, clear grid of all except Marshals/Officials. One mechanic allowed to stay with each car up to one-minute signal

1 (one) minute to start of Green Flag Lap: Audible & Visible Warning, clear grid

30 (thirty) seconds to start of Green Flag Lap: Audible & Visible Warning

Start of Green Flag Lap

During the Green Flag Lap the cars will keep in formation with no overtaking. The Safety Car will set the pace. No practice starts may be executed during the course of this lap. At the end of this Green Flag Lap, the cars will take up their grid positions.

**3.7.4.** Any cars removed from the grid after the two-minute signal or driven into the Pits on the Green Flag Lap shall be held in the Pit Lane and may only start the race after the last car to take the start from the grid has passed the Pit Lane Exit on the first racing lap, but shall only do so under the instruction of the Pit Lane Marshals.

**3.7.5.** Any Driver(s) unable to start the Green Flag Lap or start the race are required to indicate their situation by waving their hand in the air to alert the Start/Finish Line Marshals.

**3.7.6.** Any Driver(s) unable to maintain their grid position(s) on the Green Flag Lap to the extent that all other cars are ahead of him/her may complete the Green Flag Lap but must remain at the rear of the last row of the grid but ahead of any cars to be started with a time delay. Any Driver(s) unable to maintain their grid position(s) on the Green Flag Lap, but who still has other moving competing cars behind him/her may regain their allocated grid position(s). However, this must be undertaken by exercising maximum caution.

**3.7.7.** Excessive weaving to warm up tyres - using more than 50% of the track width - and falling back in order to accelerate and undertake practice starts, are both prohibited.

**3.7.8.** At the end of this lap the cars will take up their grid positions and the Safety Car will pull off the circuit into the Pit Lane. A five-second board will be shown to indicate that the grid is complete after the Green Flag Lap and that the start light sequence is imminent. The red light will be switched on and 4 (four) to 10 (ten) seconds later the red light will be extinguished to signal the start of the race.

### **3.8. Start Delayed/Abort Procedure**

**3.8.1.** If the starter deems that the start needs to be delayed, he/she will display a 'Start Delayed' board. The Countdown Procedure/Audible Warning sequence will then recommence from the one-minute board and the race may be started by use of the National Flag if all Drivers have been informed of the change of start signal. The race distance will be reduced by 1 (one) lap.

**3.8.2.** Any Driver(s) unable to start the race must indicate their situation in accordance with MSA Regulation **Q12.13.2**

Any Driver(s) deemed to have caused an aborted start will be moved to the back of the grid but ahead of any cars to be started with a time delay. Depending on individual circuit layout, the car(s) will either be removed to the back of the grid before the Green Flag Lap commences or the Driver(s) will be instructed to commence the Green Flag Lap from his/her original grid position but must, during the course of the Green Flag Lap, allow any car(s) starting behind them to overtake, thus ensuring that they take the restart from the back of the grid (but ahead of any car/s to be started with a time delay). If more than one car is penalised in this way, then their order at the back of the grid will reflect their original grid positions. The onus is on the Driver to comply and failure to do so will result in a report to the Clerk of the Course who may impose a Drive-Through Penalty or retrospective 30-second time penalty.

**3.8.2.1.** Aborted start procedure will be as follows:

**(i)** the start-delayed board is displayed, engines may be switched off and team members are allowed back onto the grid.

**(ii)** when the Operations Clerk and Clerk of the Course are happy, the countdown restarts from the one-minute signal and the grid cleared in the usual way.

**(iii)** any car(s) that then cannot be started will be pushed to the side of the track (or Pit Lane if practical) and covered by a waved Yellow Flag. If any such car(s) at the side of the track can start unaided, it may join the Green Flag Lap under the usual restrictions.

**(iv)** the remaining cars are waved off on a Green Flag Lap.

**(v)** any stalled cars are cleared to the Pit Lane if possible, or if not, to a place of safety. Cars, once within the Pit Lane, may be assisted by their team but may only start the race after the last car has taken the start and passed the Pit Lane Exit on the first racing lap.

**(vi)** the race is started, if appropriate, upon return from the Green Flag Lap in the usual way. If one Green Flag Lap has already been completed before the 'start delayed' board is shown then the race is reduced by 1 (one) lap. Then, if the start is delayed again and another lap is lost or if this causes issues with the running of the timetable the Clerk of the Course will set a new race distance.

### **3.9 Safety Car**

**3.9.1** The Clerk of the Course reserves the right to introduce a Safety Car at any time during a race until such time as the race leader has completed at least 75% of the scheduled race distance.

**3.9.2.** The Safety Car will be used in accordance with the regulations as laid down in the MSA Yearbook **Section Q, Appendix 2.**

**3.9.3.** The Clerk of the Course may impose a Drive Through penalty or retrospective time penalty upon any Competitor or team who he considers has gained an unfair advantage whether inadvertently or not from a breach of these Safety Car Regulations. If in the opinion of the Clerk of the Course during the event that one Competitor breaches these Safety Car Regulations for the benefit of another Competitor then both may be penalised.

### **3.10. Stopping a Race**

**3.10.1.** Should the need arise to stop any race, red lights will be switched on at the Startline and Red Flags will be displayed at the Startline and at all Marshals Signalling Points around the Circuit.

This is the signal for all drivers to cease circulating at racing speeds, slow to a safe and reasonable pace and to return to the starting grid, which will automatically become a Parc Fermé area.

Cars should not enter the Pits unless directed to do so or unless repairs are necessary. Work on cars already in the Pits must cease when a race is stopped and may only continue under the control of Scrutineers. Cars that are in the pit lane or which enter the pit lane may only restart from the pit lane (not the grid) after all other cars have restarted. Non-runners at the time of the stoppage can restart from the pit lane behind those referred to above.

**3.10.2.** Competitors who are able to take part in any restarted race may do so in accordance with **Q5.4 & 5.5.**

**3.10.3.** Competitors are advised that 2 (two) Red Flag race stoppages in any 1 (one) round may result in their race being placed at the end of the day's racing, time permitting. Similarly, Competitors are advised that, should the timetable be running late, their race may be postponed until later in the timetable and their scheduled race distance may be reduced by the Clerk of the Course in consultation and with the approval of the Stewards of the Meeting.

**3.10.4.** If time precludes the running of the second part of a two-part race in accordance with Regulation **3.10.2.** later in the timetable, then the terms of Regulation **3.6.3.** will be used for the purpose of determining the allocation of points for this race.

### **3.11. Re-Scrutiny/Competitor Availability**

- 3.11.1.** Any vehicle involved in an accident, or having been modified in any way subsequent to pre-Event scrutiny, must be re-presented to the Scrutineers for further examination.
- 3.11.2.** At any time during an Event, the Clerk of the Course may order that a vehicle be re-examined, even if this involves stopping a vehicle while qualifying or racing.  
Failure to comply with Regulations during a qualifying session or failure to comply with the directions of the Championship race officials to undertake a check will result in the loss of that Driver's qualifying times to that point in the session.
- 3.11.3.** If a Driver is involved in a collision or incident, he/she must not leave the circuit (except where medically evacuated) without the consent of the Clerk of the Course, failing which, any judicial action against or relating to that Competitor may be heard in their absence.
- 3.11.4.** Competitors must remain available at an Event until any protest period relating to their race has elapsed, failing which, any judicial action against or relating to that Competitor may be heard in their absence.
- 3.11.5.** Competitors cars may not be removed from the Paddock during an Event after scrutineering except for the purpose of competing in the rounds comprised in the Event or with the prior written permission of the Championship Eligibility/Safety Scrutineer and Clerk of the Course. The Championship Eligibility/Safety Scrutineer may require the competitors car to be re-scrutineered at any time.

### **3.12. Pits & Pit Lane Safety**

- 3.12.1.** Pits – Competitors must ensure that the MSA, Circuit Management and Organising Club Safety Regulations are complied with at all times.
- 3.12.2.** Pit Lane – The outer lane or lanes are to be kept unobstructed to allow safe passage of cars at all times. The onus shall be on all Drivers to take due care and drive at minimum speeds in the Pit Lane. All equipment must be moved back towards garage entrances as soon as cars leave their Pits at the start of and during qualifying sessions and races.
- 3.12.3.** Admission to the Pit Lane will be by means of Pit Lane Passes valid for that race only. People under 16 (sixteen) years of age are not allowed in the Pit Lane.
- 3.12.4.** Each Competitor is required to have 1 (one) fire extinguisher per car (minimum capacity 5kg or its equivalent) within their transporter/awning at each Event. This shall not include the extinguisher fitted to the car(s).
- 3.12.5.** During qualifying sessions and races, Drivers leaving the Pit Lane will do so on their own responsibility. However, a Marshal with a Blue Flag will warn of cars approaching.
- 3.12.6.** The Pit Lane speed limit during each Event and official Championship test day, at all times, is 30mph (48km/h) unless otherwise notified by way of a bulletin. A 'Drive Through Penalty' may be imposed for infringements during a Round but if an infringement during a Round is notified to the Clerk of the Course after the end of the Round, he may levy a fine of £10 for each km/h above the speed limit or impose a retrospective time penalty. Signs and/or lines are used to indicate the beginning and end of the area to which the speed limit applies.
- 3.12.7.** When in the Pit Lane, during all Championship official tests, qualifying sessions and races, Drivers are required to park their cars nose in towards the Pit Garages at an angle of approximately 45°, with the rear of the car facing towards the Pit Lane entrance. Cars should reverse out of the pit lane strictly under the direction of a mechanic or other team personnel.

### **3.13. Race Finishes**

- 3.13.1.** After taking the Chequered Flag, Drivers are required to progressively and safely slow down, remain behind any Drivers ahead of them and proceed directly to the designated Parc Fermé area without stopping, unless directed differently by an Official of the Meeting. Cars must remain in the designated Parc Fermé area until formally released by the Championship Eligibility/Safety Scrutineer. Drivers must keep their helmets on and their harnesses done up until they arrive in the Parc Fermé area.
- 3.13.2.** Parc Fermé Regulations will apply in the area between the Start/Finish Line and the Parc Fermé Entrance.
- 3.13.3.** Once in the Parc Fermé area, Drivers required for the podium presentations must proceed immediately to the podium. The Drivers required will be those finishing first, second and third.
- 3.13.4.** Team personnel are only allowed into the Parc Fermé Area at the invitation of the Championship Eligibility/Safety Scrutineer. Should unauthorised team personnel be present in Parc Fermé, they render their car liable to exclusion from the Event.

### **3.14. Results**

- 3.14.1.** All timesheets, grids and race results are deemed to be provisional until the Scrutineers have released all vehicles after technical inspections and after the completion of any judicial or technical procedures. The Clerk of the Course may declare the race results provisional until any investigation of video or other evidence has been completed and subsequent judicial procedures undertaken regardless of whether this investigation is as a result of a protest or merely a result of establishing if a Regulation has been broken. These results will remain provisional until such time as they are declared final by the Clerk of the Course upon completion of any judicial procedures and this will be communicated to all Competitors via a Championship Newsletter.

### 3.15. General Regulations

#### 3.15.1. Timing Modules

3.15.1.1. All Competitors will be required to fit an Electronic Self Identification Module to their car for the purpose of accurate timing. This module must be provided/owned by the teams, in place and functioning correctly for all Championship official test days, free practice, qualifying sessions and races. The setting and servicing of this item must only be carried out by properly authorised MSA licensed Timekeepers.

3.15.1.2. Direct Powered Transponders may only be purchased from: **Timing Solutions Ltd**, Unit 2, Ninian Park, Ninian Way, Tamworth, B77 5ES. <http://www.tsl-timing.com/Transponder%20Order%20Form.pdf>

3.15.1.3. Competitors may not place electronic timing equipment within 10 (ten) metres of the official Start/Finish Line or any other official timing line at any Event or official Championship test day. Any such team equipment placed within this zone will be removed.

#### 3.15.2. Adverse Weather

3.15.2.1. The rearward facing high intensity light must be illuminated at all times when visibility is reduced or when so instructed by the Clerk of the Course.

#### 3.15.3. Difficulty

If any Driver experiences a serious mechanical problem at any stage he/she must leave the track as soon as it is safe to do so and park in a position of relative safety. The car must be left in neutral and any removable steering wheel must be re-attached before the Driver gets himself behind the protective safety barriers. The Driver should stay with the car to assist recovery crews with the task of bringing the car back to the pits at the end of the session.

#### 3.15.4. Assistance

Regardless of the circumstances, once a Driver has received mechanical assistance to move his/her car from one position to another he/she is not permitted to continue within that particular session or race even if, after being moved into a position of safety, he/she feels he/she is able to continue.

#### 3.15.5. Spare Cars

Replacement cars are not permitted under any circumstances and a Competitor may only use the one car that is originally scrutineered for his/her use at each Event. Furthermore the replacement of a chassis or body shell is not permitted during an Event.

## 4. CHAMPIONSHIP PENALTIES

### 4.1. Infractions of Technical Regulations

4.1.1. Arising from post-qualifying scrutineering or judicial action - Minimum Penalty: Any car that fails post-qualifying scrutineering will only be permitted to start the race in accordance with Regulations 4.1.1.1., 4.1.1.2., 4.1.1.3. and Regulation 4.1.1.4.

4.1.1.1. The car, together with the competitors copy of the Technical non-compliance report, must be presented for re-scrutiny at the Championship's officially designated place of scrutiny for the Event, no later than 40 (forty) minutes before the time allotted in the programme of Events for the start of the race. 'Time of the essence' and 'force majeure' do not apply.

4.1.1.2. Provided that the car passes re-scrutiny then the Driver is entitled to start the race from the back of the grid 10 (ten) seconds after the official starting signal has been given.

4.1.1.3. The Driver shall be penalised by the deduction of 6 (six) points from his/her Drivers' Championship score immediately before the commencement of the Event, even if this results in a negative score.

4.1.1.4. Any Competitor who does not submit their car for re-scrutiny, or whose car fails re-scrutiny, shall be subject to the following mandatory penalties imposed by the Clerk of the Course:

(i) exclusion from the race.

(ii) a deduction of points, equivalent to two maximum scores for both Entrant and Driver if appropriate.\*

(iii) count the race as one of the rounds contributing to the Driver's total Championship score.

\*This penalty can only be varied by a Tribunal of the Motor Sports Council by application in accordance with the MSA General Regulations.

4.1.2. Arising from post-race scrutineering or judicial action - Minimum Penalty: In accordance with the MSA Regulations **C3.5.1. (a) and (b)**. For infractions deemed to be of a more serious nature, the Clerk of the Course and/or Stewards of the Meeting are to invoke the provisions of Regulation **C3.5.1 (c)**.

4.1.3. Any Competitor whose car is deemed to be ineligible under the current Technical Regulations will be subject to the penalties in accordance with the MSA Regulations, except where amended by these Sporting Regulations. In addition, the Championship Stewards may, at their discretion, apply an increased penalty that could include exclusion from part or all of the current Championship.

- 4.1.4.** If a vehicle/component is sealed for subsequent technical examination the Championship Eligibility/Safety Scrutineer, within the applicable time limit, will state to the Competitor that he will examine the vehicle/component on a stated date and time and at a specified location and the sealed items must be made available for his inspection. These arrangements are not negotiable. If a vehicle/component is not made available for an eligibility examination as required by the Championship Eligibility/Safety Scrutineer, it will be considered as ineligible and will be reported as such to the Clerk of the Course for the application of penalties laid down in the current MSA' Yearbook and these Championship Regulations.
- 4.1.5.** Any fire extinguisher system found to be incapable of being operated will be subject to a minimum fine of £100 being imposed upon the Entrant.
- 4.2. Infringements of non-Technical MSA Regulations and the Sporting Regulations issued for the Championship**
- 4.2.1.** Penalties will be applied in accordance with the current MSA Judicial Procedures, except that any Driver excluded from the results in accordance with any non-Technical Regulation will be subject to the following additional Championship penalty, which will be applied to the Drivers' Championship.
- 4.2.1.1.** Any Driver found guilty of driving which is in breach of **C1.1.5** will also have Championship points deducted commensurate with the severity of penalty imposed, i.e. formal written reprimand, 2 (two) points; fine, grid place penalty or time penalty, 3 (three) points; exclusion from qualifying session or race, 4 (four) points; exclusion from Meeting, 6 (six) points.
- 4.2.1.2.** Any Driver who is penalised during a Race under the Championship Sporting Regulations and receives an allocation of penalty points on their race licence in accordance with MSA regulations, will receive a grid slot penalty at the next race in which the Driver takes part. This penalty will also apply if a Driver receives an Exclusion from Qualifying or the race meeting at any time. The individual grid slot penalty will depend upon the severity of the penalty imposed under current MSA Yearbook **C2.1.4** and **10** as follows:
- (i)** verbal warning – 0 (zero) points: No grid slot penalty
  - (ii)** formal written reprimand – 2 (two) points: Moved back 2 (two) places
  - (iii)** fine, time or place penalty – 3 (three) points: Moved back 3 (three) places
  - (iv)** exclusion from Qualifying or Race – 4 (four) points: Moved back 4 (four) places
  - (v)** exclusion from the race meeting – 6 (six) points: Moved back 6 (six) places
- The penalty will mean that a Driver will be moved back grid slot places from their lap time grid position, i.e. if a Driver with a 4 (four) grid slot penalty had a qualifying time that was good enough for Pole Position then the Driver will start fifth on the grid.
- For avoidance of doubt, if the offence occurs at the Final Event no further penalty will apply
- 4.2.2.** Any Driver competing in the Championship may be called before a meeting of the Championship Stewards who, at their discretion, may take further action that could include exclusion from part or all of the current Championship.
- 4.2.3.** Breaches of driving standards will be dealt with firmly. If the Clerk of the Course wishes to view video evidence from the nominated TV company and/or data-logging evidence in order to assist with his enquiry into a breach of driving standards he may order that the results remain provisional and he may take judicial action at a later date. However, the use of video evidence and/or data logging evidence in all circumstances is at the sole discretion of the Clerk of the Course.
- The Championship Organisers may also, within 14 (fourteen) days of an Event and provided that the results have remained provisional, be entitled to request the Championship Stewards to enquire into the matter, notwithstanding that the Clerk of the Course and/or the Stewards of the Meeting may or may not have already investigated the incident. The Championship Stewards will be empowered to take further action if they deem it necessary, which could include exclusion from part or all of the current Championship. In addition, the MSA may call an enquiry into the matter in accordance with Background to the MSA Regulations **A3.1 (iii)**.
- 4.2.4.** Any Driver adjudged to have committed a false start or breached any part of the Start Procedure will be served with a Ten Second Penalty in accordance with MSA Regulation **Q12.5**.

## 5. TECHNICAL REGULATIONS

### 5.1. Introduction

5.1.1. The following Technical Regulations are set out in accordance with the MSA specified format and it should be clearly understood that if the following texts do not clearly specify that you can do it you should work on the principle that you cannot.

5.1.2. Everything that is not explicitly authorised and anything that is not specified:

- (i) in these Regulations,
- (ii) in the Technical manual,
- (iii) in the current User Manual/Nomenclature relating to the Renault UK Clio Cup Junior race car,
- (iv) in any official Technical Bulletin that may be published, is strictly forbidden.

The technical modifications specified in these Regulations relate to the use of the vehicle as a race car.

5.1.3. The Regulations, which govern the construction of Renault UK Clio Cup Junior race car are listed below.

5.1.4. All Competitors are reminded that it is their responsibility to ensure that their vehicle and equipment complies with the entirety of the Technical Regulations at all times during Championship official test days, free practice, qualifying sessions and races and that they have taken account of all the safety requirements of these Regulations and of the Regulations of the Championship and Event in which they are participating.

5.1.5. In interpreting any Regulation the word 'his' is deemed to include 'her' and persons referred to in the singular includes, where the context so admits, the plural.

5.1.6. The Championship Organisers reserve the right to issue additional statements concerning the rules and Regulations from time to time (Sporting and Technical Bulletins). These numbered statements will be issued to all registered Competitors via the Championship website [www.renaultsport.co.uk/internalnews](http://www.renaultsport.co.uk/internalnews) or by formal communication at the Event. Changes must have the approval of the MSA. Where clarification or amendments to the Sporting or Technical Regulations are detailed against the appropriate section number in this publication, the clarification or amendment takes place immediately.

### 5.1.7. Nomenclature

5.1.7.1. The Current version of the User Manual/Nomenclature for the Renault UK Junior Clio Cup race car incorporating all clarifications, amendments and details of updated components shall be the only active version of the document.

5.1.7.2. The parts used to build a Renault UK Junior Clio Cup race car (Current version) are described in the document named 'Nomenclature'.

These parts are divided into three categories:

- (i) Category A: No modifications are permitted. Parts in this category must remain in their original location and fulfil the function/s, for which they were originally designed,
- (ii) Category B: Only such modifications as specified in the Regulations or the Renault UK Clio Cup Junior race car (Current version) Nomenclature are permitted,
- (iii) Category C: The part is considered to be unrestricted on the express condition that the function/s for which it was originally designed is not deviated from, that it does not fulfil any additional function and that it is located in the same place as the original part.

### 5.1.8. Technical Queries

Any matter affecting Technical Regulations must be put in writing to the Championship Eligibility/Safety Scrutineer, as any claim to have received clarifications or rulings on the Regulations must be substantiated by the production, on demand, of written confirmation of such rulings.

5.1.8.1 Only those cars complying with the current Technical Regulations for the Championship and/or any amendments to the Technical Regulations issued from time to time by way of an official Championship Bulletin, in accordance with MSA Regulation **D11.1** will be allowed to compete in any round of the Championship.

5.1.8.2 Competitors must ensure that their cars comply with the conditions of eligibility and safety throughout qualifying and racing.

### 5.2. General Description

5.2.1. The Renault UK Clio Cup Junior is for Competitors participating in Renault UK Clio Cup Junior race cars (Current version), which are front-engine, front-wheel-drive saloon-cars, equipped and prepared according to these Regulations, and this shall be the only eligible vehicle.

5.2.2. The car is a racing saloon-car with four road wheels, the front pair being driven and providing steering. All wheels are fully enclosed. The Driver is provided with a closed cockpit. The bodywork envelops the chassis, engine and transmission.

5.2.3. Renault Sport Racing must supply any components supplied as part of the rolling chassis that needs to be replaced unless specifically authorised elsewhere in these Regulations.

5.2.4. Only vehicles bearing a full complement of seals will be eligible for the Championship.

5.2.5. The engine is the M5MA engine,

5.2.6. The ignition management system is modified from production standard. In all other respects, the engine is a standard series production unit to which no additional modifications may be made by the Competitor.

5.2.7. The gearbox is a Renault Sport SADEV **ST 82 / 17 RS10233 Clio CUP 2013** sequential gearbox. It has 5 forward gears + 1 reverse gear in the gearbox. Blocked 6th gear.

5.2.8. Limited adjustments are provided for suspension geometry, suspension springs and abutments, dampers and rear brake limiter to enable the car to be tuned to the requirements of individual Drivers, different circuits and

dry or wet conditions. Of these adjustments only the rear brake limiter is capable of being adjusted by the Driver while driving the car. In all other respects, modifications, changes, tuning and adjustments are strictly prohibited.

### **5.3. Safety Requirements**

**5.3.1.** Current MSA Yearbook, Section **K**, Safety Criteria Regulations, apply as relevant unless stated herein.

#### **5.3.2.1 Fire Extinguisher**

Refer to the Workshop Manual/Nomenclature for the Renault UK Clio Cup Junior race car (Current version).

**5.3.2.2.** Mandatory use of the fire extinguisher system as supplied.

The following information must be clearly displayed on each fire extinguisher:

Capacity,

Type of extinguishant,

Weight or volume of extinguishant,

Verification date of extinguisher, which must be less than 2 (two) years since the filling date or last verification date.

**All extinguishers must be serviced by the manufacturer or their agent.**

**5.3.2.3.** The Driver when seated normally in the car with seat belts and steering wheel in place, must be able to activate the fire extinguisher manually, as must any person outside the car. The means of triggering the extinguisher from the outside of the car must be positioned close to the main circuit breaker and must be denoted by a red 'E' within a white circle, of at least 10cm diameter with a red edge.

The fire extinguisher must be located in the original position. Outlets must not point directly at the Driver and must be suitable for the type of extinguishant.

#### **5.3.2.4. During Events**

All extinguisher systems must be in the 'ARMED' condition (i.e. be capable of being operated without the removal of any safety device) at all times while competing or practising, including post-Event scrutineering.

**5.3.2.5.** The fire extinguisher cannot be disarmed in any Parc Fermé area without the specific permission of the Championship Eligibility/Safety Scrutineer.

#### **5.3.3. Main Circuit Breaker**

Refer to the User Manual/Nomenclature for the Renault UK Junior Clio Cup race car (Current version).

**5.3.3.1.** Mandatory use of the circuit breaker supplied.

**5.3.3.2.** The Driver when sitting normally in the car with seat belts fastened and steering wheel in place must be able to shut off all electrical circuits and stop the engine by means of a circuit breaker (which has been isolated to prevent arcing). The circuit breaker must also be able to be operated from the exterior of the car by means of a clearly indicated switch.

**5.3.3.3.** The switch must be located on the left hand side scuttle panel close to the fire extinguisher trigger point. The location must be identified by a Red Spark on a white edged blue triangle with a base of at least 12cm.

**5.3.3.4.** The circuit breaker when 'operated' must isolate all electrical circuits, data loggers, transponders, etc. in accordance with the current MSA Yearbook, Section **K8**.

When the circuit breaker is 'operated' there must be no power source capable of keeping the engine running.

#### **5.3.4. Roll-Over Protection**

Refer to the User Manual/Nomenclature for the Renault UK Junior Clio Cup race car (Current version).

**5.3.4.1.** Roll over protection consists of a fully welded steel cage.

**5.3.4.2.** Mandatory use of the roll cage 'as supplied'. No modifications are permitted.

**5.3.4.3.** Mounting of the roll cage into the body shell must respect the requirements of MSA Yearbook **K1.3.2**

The standard FIA homologated foam must remain in the original position [longitudinal and diagonal members] above the Driver's head.

Additional foam can be applied to other areas of the roll cage providing it is compliant with this application and the current MSA Yearbook, Section **K**.

Suitable protection should be applied to the underside of the steering column bracket.

**5.3.4.4.** **Compulsory use of the current Renault UK Clio Cup Junior specification driver's door with the energy absorption foam, composite door panel and window must be used.**

#### **5.3.5. Seat**

Refer to the User Manual/Nomenclature for the Renault UK Clio Cup Junior race car (Current version).

**5.3.5.1.** Mandatory use of the Renault Sport seat **and comply with FIA Homologation Standard 8855-1999 or FIA Standard 8862-2009**. Any additional padding or covering placed on the seat must be fire retardant to FIA standard 8855 -1999.

#### **5.3.6. Lights**

Refer to the User Manual/Nomenclature for the Renault UK Clio Cup Junior race car (Current version).

**5.3.6.1.** All cars must be fitted with rear high intensity lights.

**5.3.6.2.** All cars must be fitted with two rear brake lights.

**5.3.6.3.** All cars must use the rear lights in their original configuration as defined in the Workshop Manual.

**5.3.6.4.** All cars must be fitted with operating headlamps, and bulbs to the original specification.

**5.3.6.5.** It is not permitted to tint or paint the front or rear lighting units.

**5.3.6.6.** All lights detailed in Regulation **5.3.6.1.**, Regulation **5.3.6.2.** and Regulation **5.3.6.4.** must be in working order throughout the entire Event and must be able to be switched on by the Driver when seated normally in the car.



### 5.3.7. **Fuel Tank/Fuel Lines**

Refer to the User Manual/Nomenclature for the Renault UK Clio Cup Junior race car (Current version). Mandatory use of the fuel tank as supplied. The Championship Organisers reserve the right to nominate modifications to the fuel tank should the need arise.

### 5.3.8. **Safety Harness**

Refer to the User Manual/Nomenclature for the Renault UK Clio Cup Junior race car (Current version).

#### 5.3.8.1. Mandatory use of the safety harness as supplied.

#### 5.3.8.2. The wearing of two shoulder straps, one abdominal strap and two straps between the legs is mandatory.

#### 5.3.8.3. The straps must be securely fixed to the car and the anchorage points should be arranged in accordance with the current MSA Yearbook, **Section K**, and Drawing No. FIA253-42.

#### 5.3.8.4. Following an incident where the safety harness has been subject to high stress the complete harness must be replaced.

It is permitted to use shoulder pads on the shoulder straps of the safety harness.

### 5.3.9. **Rear View Mirrors**

Refer to the User Manual/Nomenclature for the Renault UK Clio Cup Junior race car (Current version).

#### 5.3.9.1. Mandatory use of the external rear view mirrors as supplied.

#### 5.3.9.2. All cars must be equipped with two rear view mirrors, one on each side, and one internal mirror, which offer the Driver a rearward view of either side of the vehicle. It is permitted to fit a replacement interior mirror of different size.

### 5.3.10. **Glass Safety Film**

(i) It is permitted to apply a film to side and rear windows.

(ii) The film shall be 'non tinted'.

(iii) It is only permitted to use: 6000 072 744.

### 5.3.11. **Driver's Window Net**

The Driver's window net must be used at all times while the car is on the circuit.

### 5.3.12 **Driver's Window**

Mandatory use of the Junior drivers window part number TBA

### 5.3.13 **Driver Equipment:**

Overalls: Drivers must wear overalls as well as gloves, long underwear, a balaclava, socks and shoes / boots homologated to FIA 8856-2000 standard, as detailed in FIA Appendix L, Chapter III Article 2.

Safety Helmets: These must be to the standards specified in the current MSA Yearbook, section K10.3.1 a (i.e. be acceptable for International and MSA events) and must incorporate an FIA homologated head and neck protection system (FHR) fitted in accordance with FIA regulations. It is highly recommended that the helmet visor be fully closed whilst on circuit.

## 5.4. **General Technical Requirements and Exceptions**

### 5.4.1. All vehicles must comply with MSA general Technical Regulations and the relevant parts of Sections **J & Q** of the current MSA Yearbook unless otherwise stated herein.

### 5.4.2. All components must be homologated by Renault Sport Racing for the current Renault UK Clio Cup Junior.

### 5.4.3. Only organisations holding the approval of the current Renault UK Clio Cup Junior Organisation are allowed to manufacture and supply cars and components, including spares. The sole approved supplier for all above items unless otherwise stated shall be Renault Sport Racing.

### 5.4.4. All references to standard parts and/or part numbers and/or materials in these Regulations shall be interpreted as references to Championship approved manufacturers' or partners' original specification(s) relative to the current Renault UK Clio Cup Junior, or to official sample parts supplied and certified by the manufacturers and builder. In the case of dispute, reference will be made to these specifications, drawings and/or samples.

### 5.4.5. The car must be constructed and assembled in total conformity with the original design. In particular:

#### 5.4.5.1. All components used in the construction and assembly of the car must be capable of being identified by an approved identification mark, except where modifications and adjustments are specifically permitted by these Regulations.

#### 5.4.5.2. Certain components will be identified by holograms or manufacturers' identification marks. These components will only be eligible while the tags/identification marks are intact, legible and positioned in conformance with the requirements of the Workshop Manual/Nomenclature.

If parts have been supplied without holograms the part may be authenticated and a hologram fitted, provided an audit trail and compliance with the component specification can be demonstrated.

#### 5.4.5.3. The reinforcement of any component or joint by the addition of material either separately or by increase in the gauge or section of the material is not permitted.

#### 5.4.5.4. The re-distribution of weight in the car, by reducing the gauge or section of material in any component and by adding ballast or increasing material elsewhere, is not permitted.

#### 5.4.5.5. Except where specifically permitted, the structural and aerodynamic performance of the car and performance of the engine must not be changed by modifying the shape of any component e.g. by the addition or removal of any material or by deforming the original material.

#### 5.4.5.6. The addition of any element having an aerodynamic influence is forbidden. It is emphasised that the aerodynamic shape of the car must remain absolutely standard i.e. all surfaces wetted by the air stream must not be modified in any way even by the addition of adhesive tape or other temporary materials.

- 5.4.6.** Any work on the car in the following areas:  
 The structure,  
 The bodywork,  
 The mechanical elements,  
 The electrical system,  
 The accessories,  
 must be carried out in accordance with the methods prescribed by the Championship in order to ensure that the car retains its original configuration.
- 5.4.7.** Replacement parts and technical assistance will be available at all Championship official test days, free practice, qualifying sessions and races.
- 5.4.8.** It is the Entrant's/Driver's responsibility to ensure that only eligible components are used and that all replacement parts fitted to the vehicle comply with the Regulations before such parts are fitted.
- 5.4.9.** From time to time it will be necessary to approve alternative equivalent components. Only components approved as alternatives and published as such by the Championship Organisers and/or their appointed representatives in official amendments to these Regulations are eligible for the current Renault UK Clio Cup Junior.
- 5.4.10. Repairs**
- 5.4.10.1.** The principle of the championship requires that cars shall be of uniform performance. In all cases, the repair or replacement of body panels must be carried out in accordance with the methods prescribed by the Championship and detailed in the Repair Manual and in the Nomenclature edition of the User Manual relating to the Renault UK Clio Cup Junior race car (Current version).  
**For avoidance of doubt all repairs must conform to official Renault Bodyshop standards.**
- 5.4.10.2.** Any repairs not undertaken by direct replacement with standard parts will only be permitted if it can be demonstrated that such repairs are incapable in any way of enhancing the performance of the car. It is the Entrant's responsibility to provide such demonstration to the Championship Eligibility/Safety Scrutineer before the car is used but the decision of the Scrutineer whether to accept the demonstration or not will be taken as final.
- 5.4.10.3.** Any car that shows obvious signs of having been reinforced in any areas will automatically be deemed not to comply with the Technical Regulations governing the Renault UK Junior Clio Cup race car (Current version).
- 5.4.11. Presentation**  
 At the start of each free practice, qualifying session or race, the cars must be clean and in good order. The Championship Organisers reserve the right to forbid cars not meeting this requirement from taking part.
- 5.4.12. Fasteners**
- 5.4.12.1. Nuts and Bolts**  
 Nuts and bolts must respect the category of the Nomenclature. Nuts and bolts are classed as Category C and are unrestricted on the following conditions:  
 (i) That the standard diameter is retained,  
 (ii) That the standard thread pitch is retained,  
 (iii) That the original material must be retained.  
 Steel construction must be of equal or higher grade than the standard part.
- 5.4.12.2.** Rivets must respect Regulation **5.4.14.1. (i)** and Regulation **5.4.14.1. (iii)**. the use of additional fastening devices, e.g. bolts, screws, rivets is forbidden.
- 5.4.12.3.** The use of bonding material (adhesives, glues) to reinforce, replace or supplement any bolted, screwed or riveted joint is forbidden.
- 5.4.12.4.** It is permitted to use Loctite RC 75/AAV (Retaining Compound) or equivalent, to supplement any screw or bolt thread.
- 5.4.12.5.** It is permitted to repair faulty threads by the use of Keen Inserts/Helicoils. Where thread inserts are utilised the original thread diameter and pitch must be respected.
- 5.4.12.6.** The application/use of **Category C** fasteners will be considered as such: that the fastener must adapt to the environment and not modify the environment to the fastener.
- 5.5. Chassis**  
 Refer to the User Manual/Nomenclature for the Renault UK Clio Cup Junior race car (Current version).
- 5.5.1.** Cars shall be identified by chassis numbers and seals that are attached to non-detachable parts of the main structure by the Championship Eligibility/Safety Scrutineer.
- 5.5.1.1.** Only authorised chassis sold by Renault Sport Racing will be eligible for competition.
- 5.5.1.2.** Only complete cars are permitted and not cars assembled from various spare parts. If doubt exists over the history or integrity of a car, the Competitor will have to provide a written audit trail of the car's history, including details of the engine, gearbox and chassis.
- 5.5.2.** The body shell may not be modified in any way, other than as specified in:  
 (i) These Regulations,  
 (ii) The User Manual/Nomenclature for the Renault UK Clio Cup Junior race car (Current version).  
 Whether this is by the removal or addition of material.
- 5.5.3. Towing Eyes**  
 The tow eyes installed as standard at the front and rear must be retained and in good condition.

## 5.6. Bodywork and Measurements

Refer to the User Manual/Nomenclature for the Renault UK Clio Cup Junior race car (Current version).

5.6.1. The sections of bodywork may not be modified in any way other than as specified in:

(i) These Regulations,

(ii) The User Manual/Nomenclature for the Renault UK Clio Cup Junior race car (Current version).

Whether this is by the removal or addition of material.

5.6.2. It is not permitted to bridge bodywork joint lines with adhesive tapes.

5.6.3. Tape applied to bodywork must follow the original shape of the bodywork and must not be used to modify the standard profile.

Small strips of tape whose sole purpose is to cover and protect clips and other bodywork fasteners are permitted.

## 5.6.4. Crash Structure

5.6.4.1. On the grounds of safety, all cars while on the track must be fitted with a crash structure that is attached to the main structure of the vehicle, in the original position and with the correct fixings.

5.6.4.2. Should the front bumper and crash structure become detached from the vehicle or sustain damage that may be considered to compromise its structural integrity, the car will immediately be shown the Black Flag with orange disc. At this point the car must call at its Pit Bay for repairs on the next lap.

## 5.7. Main Dimensions

Refer to the User Manual/Nomenclature for the Renault UK Clio Cup Junior race car (Current version).

The wheel base and track (front and rear) must remain within the range of permitted values using the original suspension parts.

5.7.1. Ground clearance:

(i) Over the entire surface of the vehicle must be a minimum of 4cm,

(ii) Will be measured with the Driver on board (wearing his complete racing apparel),

(iii) Will be measured with the car and Driver in the condition in which they cross the Finish Line or at any other time during an Event and without the removal of any solid or fluid matter including fuel.

## 5.8. Engine

Refer to the User Manual/Nomenclature for the Renault UK Clio Cup Junior race car (Current version).

No modifications to the engine and ancillaries or engine management systems are permitted.

5.8.1. A series production Renault M5MA engine is modified and prepared to a uniform performance specification for the Championship by the designated engine supplier, which has been approved by the Championship Organisers.

Any repairs, rebuilding or tuning to the engine must be carried out by the Championship's officially appointed representative.

## 5.8.2 Engine Sealing

5.8.2.1. Only engines supplied by the designated engine supplier and sealed with specification 2017/2018 seals are eligible for the current Renault UK Clio Cup Junior Championship.

Pre-season engine power inspection

Any engine used in the Renault UK Clio Cup Junior car and participating in the current Renault UK Clio Cup Junior Championship must have been checked and sealed by the approved Renault Sport engine partner.

The competitor will be responsible for the transport and bench test costs.

5.8.2.2. During an Event the Eligibility Scrutineer is the only person allowed to remove a seal if a minor intervention requires it. He must be present during the intervention and will fit a new official Renault Sport Racing seal immediately after.

5.8.2.3. The engine and Electronic Control Unit (ECU) are sealed using metallic, sealing strips or paint sealing systems. It is the Entrant's/Driver's responsibility to maintain the seals unbroken and to protect all such seals from damage or loss, as the eligibility of the relevant components and assemblies depends upon a full complement of seals being in place.

5.8.2.4. The seals may only be broken with the permission of the Championship Eligibility/Safety Scrutineer and/or his appointed representative.

5.8.2.5. Only engines with a full complement of seals will be eligible for repair and rebuild.

5.8.2.6. Any engine not bearing Renault Sport Racing seals, or of which one or more seals are missing, shall be considered to be a non-compliant with the Technical Regulations.

5.8.2.7. In the event that one or more seals shall be found to be missing or not in compliance:

(i) At pre-Event scrutineering: the engine must be replaced for the car to be eligible to take part in qualifying. The engine with the missing seal(s) shall be retained by the Championship Eligibility/Safety Scrutineer for a thorough examination. It will be rebuilt, sealed and made available for competition use at a cost payable by the Competitor.

(ii) During the Event: this shall be considered to be a non-compliance with the Technical Regulations and will automatically be the subject of a report to the Clerk of the Course.

5.8.2.8. At the Championship Organisers' discretion, an engine may be retained at the end of the race for further examination.

The Championship Organisers reserve the right to require a Competitor to exchange an engine for a new replacement at any time. This requirement is designed to ensure that the principle of the Championship is seen to be maintained in accordance with Regulation 5.2.

**5.8.2.9.** At the Championship Organisers' discretion, an engine may be retained at the end of the race for further examination. The Championship Organisers reserve the right to require a Competitor to exchange an engine for a replacement at any time. Any engine change requested by the Competitor must be validated by the Championship Officials.

### **5.8.3. Lubrication System**

Refer to the User Manual/Nomenclature for the Renault UK Clio Cup Junior race car (Current version).

**5.8.3.1.** Mandatory use of TOTAL QUARTZ 10W60 engine lubricant. The use of additional additives is strictly forbidden. The Championship Organisers reserve the right to nominate an alternative if the conditions arise.

**5.8.3.2.** No oil replenishment is allowed during qualifying or during the race.

### **5.8.4. Cooling System**

Refer to the User Manual/Nomenclature for the Renault UK Clio Cup Junior race car (Current version).

### **5.8.5. Induction System**

Refer to the User Manual/Nomenclature for the Renault UK Clio Cup Junior race car (Current version).

The original engine air filter element and casing may not be modified in any way and must be fitted at all times during an Event. It may only be removed for the sole purpose of cleaning.

### **5.8.6. Engine Electrical System**

Refer to the User Manual/Nomenclature for the Renault UK Clio Cup Junior race car (Current version).

#### **5.8.6.1. Engine Management Computer**

Only engine Electronic Control Units that are numbered and carry unbroken seals are eligible for the Renault UK Clio Cup Junior race car. The Championship Organisers retain the right to provide replacement engine Electronic Control Units before free practice, qualifying session or race at any Event, or at any Championship official test day.

**5.8.6.2.** ECU map – the only ECU map that is permitted within the Renault UK Clio Cup Junior Championship is one defined by Renault Sport Racing.

### **5.9. Suspension**

Refer to the User Manual/Nomenclature for the Renault UK Clio Cup Junior race car (Current version).

**5.9.1.** Compulsory use of the original Renault UK Junior Clio Cup race car (Current version) suspension as supplied.

The suspension may not be modified in any way, other than as specified in:

(i) These Regulations,

(ii) The User Manual/Nomenclature for the Renault UK Clio Cup Junior race car (Current version).

#### **5.9.2. Permitted changes to the original specification:**

**5.9.2.1.** Adjustment of the suspension geometry is free, but only within the range of adjustment provided.

Adjustment of camber and tracking angles are free, but only within the range provided by the parts as detailed in the User Manual/Nomenclature for the Renault UK Clio Cup Junior race car (Current version).

#### **5.9.2.2. Rear Camber and Tracking**

**5.9.2.2.1.** It is not permitted to place the shims in opposing planes.

**5.9.2.2.2.** The minimum number of shims must be used to achieve the desired adjustment. It is not permitted to use multiple smaller denomination shims to make up a larger shim. (I.e. 6x10" shims cannot be used in place of 1x1° shim).

#### **5.9.3. Shock Absorbers**

(i) Mandatory use of shock absorbers as supplied.

(ii) Bump rubbers must be used as supplied from Renault Sport Racing.

(iii) No modification to the damper valving is permitted.

**5.9.4.** It is not permitted to apply any additional paint or surface treatment system to any suspension components. All components must remain as supplied.

#### **5.9.5. Suspension Springs, Front and Rear**

**5.9.5.1.** Mandatory use of springs as supplied.

Mandatory use of the bump rubber supplied.

### **5.10. Transmission**

Refer to the User Manual/Nomenclature for the Renault UK Clio Cup Junior race car (Current version).

#### **5.10.1. Clutch**

**5.10.1.2.** Mandatory use of the original Renault UK Clio Cup Junior race car (Current version) clutch system as supplied.

#### **5.10.2. Gearbox**

**5.10.2.1.** Mandatory use of the five-speed and reverse sequential Renault UK Junior Clio Cup race car (Current version) gearbox.

**5.10.2.2.** Once supplied, the gearbox and ancillaries supplied with it may not be modified in any way whatsoever except with the written permission of the Championship Eligibility Scrutineer

**5.10.2.3.** All cars must be equipped with a reverse gear in normal working order. It must be selectable at any time during an Event by the Driver seated in his normal driving position, with the engine running.

#### **5.10.2.4. Repairs**

Any repairs undertaken on the gearbox unit must comply with the procedures detailed in User Manual/Nomenclature for the Renault UK Clio Cup Junior race car (Current version).

**5.10.2.5.** Mandatory use of MOTUL Gear Competition 75W140 gearbox lubricant

**5.10.2.6.** The use of additional additives is strictly forbidden.

**5.10.2.7.** The Championship Organisers reserve the right to nominate an alternative gearbox lubricant if the conditions arise.

#### **5.10.3. Differential and Final Drive**

**5.10.3.1.** It is mandatory to use the final drive as supplied.

**5.10.3.2.** The lightening and removal of material from the transmission system is forbidden. No modification to the prevailing torque within the differential mechanism is permitted.

#### **5.11. Electrics**

Refer to the User Manual/Nomenclature for the Renault UK Clio Cup Junior race car (Current version).

##### **5.11.1. Telemetry**

During Championship official test days, free practice, qualifying sessions and races it is forbidden to use:

- (i) any/all telemetry systems and associated electrical equipment,
- (ii) pit to car radios and vice versa.

##### **5.11.2. Data Logging**

**5.11.2.1.** The only data acquisition system(s) fitted is that specified by Renault Sport Racing.

**5.11.2.2.** The only lap timing system(s) fitted is that specified by Renault Sport Racing.

**5.11.2.3** The Championship Organisers reserve the right to download, access and analyse any information at any time during an Event.

**5.11.2.4** The organisers reserve the right to publish the data of the fastest qualifying time at each championship event.

**5.11.2.5** It is compulsory to fit the GPS Receiver (8201406558) which must remain working at all times.

##### **5.11.3. Battery**

(i) Compulsory use of 12-volt battery as supplied.

(ii) Compulsory insulation of battery terminals to protect from short-circuiting and producing sparks.

The battery earth lead, if not readily distinguishable, must be identified by a yellow marking.

##### **5.11.4. Charging Circuit**

**5.11.4.1.** Compulsory use of 12-volt (nominal) alternator as supplied.

**5.11.4.2.** Charging circuit must be operational at all times while the engine is running.

##### **5.11.5. Starter**

**5.11.5.1.** Compulsory use of the starter as supplied.

**5.11.5.2.** Competitors must be able to demonstrate, at any time during an Event, that the starter is capable of starting the engine with electrical or other source of energy carried aboard, and able to be operated by the Driver when seated normally.

##### **5.11.6. Wiring Loom**

**5.11.6.1.** Compulsory use of the wiring loom as supplied.

**5.11.6.2.** No modifications are permitted to the wiring loom except with the written permission of the Championship Eligibility Scrutineer.

**5.11.6.3** Any repairs carried out to the wiring loom must be by a Renault UK approved representative.

**5.11.7.** Compulsory use of the dashboard as supplied.

#### **5.12. Brakes**

Refer to the User Manual/Nomenclature for the Renault UK Clio Cup Junior race car (Current version).

**5.12.1.** Compulsory use of the original Renault UK Clio Cup Junior race car (Current version) brake system.

No modifications may be made to the master cylinders, callipers, discs or any other part of the braking system.

##### **5.12.2. Brake Pads**

**5.12.2.1.** Brake pads must fit in unmodified standard callipers.

**5.12.2.2.** The mandatory brake pad is:

Front: PFC 013 reference 82 01 577 773

Rear: PFC 011 reference 82 01 490 462

No other manufacturer or friction material may be used.

**5.12.3.** The use of air cooling arrangements to the rear brakes is forbidden.

It is permitted to fit a protective covering to the front flexible brake hoses.

### 5.13. **Wheels/Steering**

Refer to the User Manual/Nomenclature for the Renault UK Clio Cup Junior race car (Current version).

5.13.1. Mandatory use of Renault Sport Racing wheel.

#### 5.13.2. **Steering Wheel**

Refer to the User Manual/Nomenclature for the Renault UK Clio Cup Junior race car (Current version).

It is mandatory to use a Renault Sport Racing steering wheel.

### 5.14. **Tyre**

5.14.1. Make: Michelin

5.14.2. Type & Size

Michelin Pilot Sport 3 205-40/17 ZR 84W

5.14.2.1. The Championship Organisers reserve the right to nominate an alternative if the conditions arise.

All modifications to the tyres, including re-cutting, re-treading or surface treatments, are forbidden.

The use of heated covers or any other means of modifying or maintaining the temperature of the tyres is forbidden.

5.14.3 Definitions:

New tyre: Tyre not ever having being used before, supplied by the official controlled tyre supplier.

Spare tyre: Tyre replacing a damaged one that was fitted on the car.

5.14.4 Usage:

The use of tyres and the presence of tyres in the Pits at any time during an Event in the Renault UK Clio Cup Junior or the test sessions are governed by the provisions of these Sporting Regulations and Technical Regulations.

5.14.4.1 Any change being made to the tyres in order to modify or to maintain the original performance of the tyres is forbidden. The Organisers reserve the right, during any Event or Collective Test, to take samples of rubber from the tyres in order to conduct analysis in a specialised laboratory with the aim of checking the characteristics of them, and to verify its compliance with the originals.

5.14.4.2 Scrutineers will check that all cars are using the authorised tyres throughout the Event. Any observed breach will immediately be referred to the Clerk of the Course and the Competitor concerned will be informed.

5.14.4.3 Limitations applying to the use of tyres. The regulations limiting the use of tyres will apply to all qualifying and races. The limitations will take the form of a determined quantity of identified tyres according to the type and dimensions specified above.

#### 5.14.4.4 **Limitations and quotas applying to the use of tyres per car**

##### **A – Pre-event test sessions**

The use of tyres is free provided that the type and dimensions are as authorised by the Technical Regulations and supplied by the official controlled tyre supplier.

**B - Event:** For the qualifying session and two races only the use of the 4 (four) nominated tyres is permitted.

#### 5.14.4.5 **Use of spare tyres**

It is the responsibility of every competitor to present his car equipped with tyres capable of completing the qualifying session and the races. If this requirement is not met, the Eligibility Scrutineer may prevent the car from joining the session in question.

5.14.4.6 In those exceptional cases where, in the judgement of the Championship Eligibility/Safety Scrutineer, damage to tyres through no fault of the Competitor makes further participation in an Event impossible, supplementary spare tyres may be nominated and used. Supplementary tyres are to be selected by the Eligibility/Safety Scrutineer at the start of the event and recorded on the Tyre Nomination Form.

5.14.4.7 Any tyres damaged through misuse will be subject to supplementary tyres selected by the Eligibility/Safety Scrutineer. The selection is to be entirely at the discretion of the Eligibility/Safety Scrutineer. In this case, the Clerk of the Course will impose a penalty of 6 (six) grid places on the Competitor.

#### 5.14.5.1 **Marking and checking procedure**

Each tyre is registered with a specific marking on the tyre and Competitors will be held responsible for matching the specific marking on the Tyre Nomination Form and the specific marking on the tyres fitted on his / her car. Any tyres with specific markings that are not included in the Tyre Nomination Form will be regarded as technical non-compliance. Any infringement of the scheduled times for marking of tyres or any other similar deadlines may result in a financial penalty being imposed by the Clerk of the Course.

5.14.5.2 Each Competitor must record on the Tyre Nomination Form the specific marking of the 4 (four) nominated tyres. The Tyre Nomination Form must be signed by the Competitor and submitted to the Technical Support Vehicle before the first qualifying session. The Series Eligibility/Safety Scrutineer or his appointed representative will sign for receipt and return the back copy. The onus is on the Competitor to ensure that the completed Tyre Nomination Form is deposited with the Technical Support Vehicle before the first qualifying session. Failure to do so will be the subject of a report to the Clerk of the Course.

5.14.5.3 The tyres nominated in accordance with Regulation 5.14.5.2 must be tyres that have been recorded in the Vehicle Technical Passport for the season.

5.14.5.4 During an Event, checks will be made by the Championship Eligibility/Safety Scrutineer or his appointed representative to ensure compliance between the tyres used and specific markings recorded on the Tyre Nomination Form. At the end of the race all placed cars will automatically be checked for compliance with this tyre Regulation. Non-compliance at any time during an Event will be the subject of a report to the Clerk of the Course.

- 5.14.6.** It is only permitted to inflate tyres with air, no other medium may be used.
- 5.14.7** It is not permitted for any Driver to utilise a qualifying session as free practice on un-nominated tyres. The use during qualifying of unauthorised tyres will result in times being disallowed and use during races will result in exclusion from the race(s) concerned.

## **5.15 Weight**

**5.15.1** The principle is to equalise the performance of the car and Driver combination. The minimum car/driver weights at the completion of every free practice, qualifying session and race must be in accordance with Regulation **5.15.2** and **5.15.3**.

**5.15.2** Prior to the first on-track activity of the event in which the vehicle / Competitor is entered the Driver will be weighed. For the **2018** season a specific allowance of 80 kg will be made for the Driver weight unless this is subsequently amended by an Official Renault UK Clio Cup Junior Championship Bulletin. Where the Driver weight is below the specified allowance the weight difference involved must be carried within the vehicle at all times.

**5.15.3** The minimum weights will be as follows:

(1) Minimum weight of car and Driver: 1,160kg

(11) Minimum weight of car minus Driver: 1,080kg plus any difference calculated in **5.15.2**. The minimum weight is 'in the condition in which the car and Driver (wearing his complete racing apparel) are presented at any other time during an Event and without the addition or removal of any solid or fluid matter including fuel. For the purpose of the Regulation, an Event is deemed to include any transfer to a place of post-qualifying or post-race scrutiny as directed by an Official.

**5.15.3.** It is forbidden to add any liquid(s) or other material(s) to the car, or to substitute any part(s) for a heavier one during free practice, qualifying session or race.

**5.15.4.** If ballast is required to achieve the minimum weight, this must be in the form of official ballast plates. The specific components and techniques are detailed in the User Manual/Nomenclature. It must be possible for seals to be applied to the ballast, should the Championship Eligibility/Safety Scrutineer deem this necessary.

**5.15.5** If the car carries ballast in order to meet the weight required by the Regulations, a mandatory declaration must be made by the Competitor about this ballast to the Clio Cup Junior Championship Eligibility/Safety Scrutineer **and recorded in the Technical Passport.**

## **5.15.7 Minimum weight check/racing weight check**

Minimum weight can be checked at any time during an event, on the understanding that it is forbidden to add any oil, other liquids or extinguishant before weighing. Apart from the competitor or his/her representative, only the Scrutineers and Officials may enter the weighing area. No work whatsoever may be performed in this area unless it has been approved by Officials.

## **5.15.8 Weighing**

**5.15.8.1** Cars must comply at all times during an Event with the minimum weights set out above. All cars must exceed the minimum weight limitations at all times during qualifying and the races. No weight tolerance will be granted.

**5.15.8.2** The weighing equipment designated by the Organisers will be the only scales considered as valid.

**5.15.8.3** After qualifying and/or the race every classified car may be weighed. If a driver wishes to leave his car before it is weighed he must ask the Championship Eligibility Scrutineer to weigh him in order that this weight may be added to that of the car.

**5.15.8.4** The relevant car may be excluded should its weight be less than that specified in the Technical Regulations when weighed under the regulations above, save where the deficiency in weight results from the accidental loss of a component of the car.

**5.15.8.5** No substance may be added to, placed on, or removed from a car after it has been selected for weighing or has finished a qualifying session or a race or during the weighing procedure.

**5.15.8.6** No one other than Scrutineers and Officials may enter or remain in the specified area without the specific permission of the Championship Eligibility Scrutineer.

**5.15.8.7** Any breach of these provisions for the weighing of cars may result in the deletion of any number of the relevant driver's qualifying times or exclusion from the race.

## **5.16. Fuel**

**5.16.1.** The only permitted fuel shall be Unleaded Pump Fuel meeting the requirements of the Terminology Section B of the MSA Yearbook **2018** for fuel to BS7800 specification. The Championship Organisers reserve the right to nominate an alternative grade of fuel.

**5.16.2.** Once supplied, nothing may be added to the fuel.

## **5.16.3. Source**

**5.16.3.1.** The Championship Organisers will designate a supplier of fuel who will be required to supply a high quality, consistent and traceable fuel for each Event and Championship official test day. The fuel supplier for the Championship will be WP Racing. The Championship Organisers reserve the right to nominate an alternative supplier if the conditions arise.

- 5.16.3.2. During an Event and free practice, Competitors may only use fuel supplied by the designated supplier, which is deemed the Championship Control Fuel.
- 5.16.3.3. The onus is on the Competitor to ensure that they have a demonstrable audit trail for any fuel purchased.
- 5.16.3.4. Refuelling is not permitted during qualifying, on the starting grid or during a race.
- 5.16.3.5. Any storage of fuel on board the vehicle at a temperature below ambient temperature is forbidden.
- 5.16.3.6. The use of any specific device (whether on board or otherwise) to decrease the temperature of the fuel below the ambient temperature is forbidden.

#### 5.16.4. Fuel Testing

- 5.16.4.1. Fuel testing may be carried out at any time before, during or after an Event on the instruction of the Clerk of the Course or Championship Eligibility/Safety Scrutineer.
- 5.16.4.2. Fuel testing will be carried out in accordance with the current MSA Yearbook, Regulation **D34.1**
- 5.16.4.3. The Championship Eligibility/Safety Scrutineer or his appointed representative will take a sample of approximately 1 (one) litre of fuel from the nominated supply and will seal the container. Fuel samples taken from competing cars will be analysed against the sample taken by the Championship Eligibility/Safety Scrutineer. The fuel from the cars must in all respects be identical with the original sample.
- 5.16.4.4. Where facilities exist to carry out comparison testing at the circuit, a sample will be taken from the car that will be retained in Parc Fermé until the results are declared. If the test shows any discrepancies then formal samples will be taken as detailed above.
- 5.16.4.5. After each qualifying session and race a minimum of 3 (three) litres of fuel from the fuel cell of the competing car must be made available to Championship Eligibility/Safety Scrutineer or his appointed representative for analysis.
- 5.16.4.6. Compliance with Regulation **5.15.2**. Will be checked prior to removal of the fuel.
- 5.16.4.7. Competitors must ensure that no fuel contamination occurs.
- 5.16.4.8. No introduction into the air intake system of water, nitrous oxides or any other agent is permitted.
- 5.16.4.9. Failure to comply with these fuel Regulations will be the subject of a report to the Clerk of the Course and the Competitor will be deemed to be in breach of these Technical Regulations.

#### 5.17. Silencing and Exhaust

Refer to the user Manual/Nomenclature for the Renault UK Clio Cup Junior race car (Current version).

- 5.17.1. It is mandatory to use the standard exhaust system, catalytic converter and silencer, as supplied.
- 5.17.2. The exhaust system, catalytic converter and silencer must remain unmodified and be fitted at all times.
- 5.17.3. The complete exhaust system up to the end of the final pipe shall remain airtight at all times.
- 5.17.4. The catalytic converter must be in good working order.
- 5.17.5. All cars must conform to the current MSA noise requirements as detailed in the MSA Yearbook. Section **J** - Technical.

#### 5.18. Lubricant Testing

Specified lubricants can be found within the User Manual/Nomenclature for the Renault UK Clio Cup Junior race car (Current version). Once supplied, nothing may be added to the lubricants.

- 5.18.1. Lubricant sampling may be carried out at any time before, during or after an Event on the instruction of the Clerk of the Course or Championship Eligibility / Safety Scrutineer
- 5.18.2. The procedure for sampling will be that four samples will be taken and placed in four new containers. These will be identified and allocated as:
  - One for the analysis laboratory specified by the Organisers
  - One for the Competitor
  - One for the Organisers
  - One which may be sent to the MSA, either via an MSA Official or registered carrier
- 5.18.3. Containers will be identified and sealed by the Championship Eligibility Scrutineer in the presence of the Competitor.
- 5.18.4. Testing of the lubricant sample will be performed by a specialist analysis laboratory nominated by the Organisers and transported by registered carrier or a Championship Eligibility Scrutineer.
- 5.18.5. The sample reserved for the MSA will only be used to give a second expert opinion in case of any dispute between the Competitor and the Organisers



## 6. COMMERCIAL REGULATIONS

The following Commercial Regulations are “contractual” between the Entrant and / or Driver and the Organisers and/or Championship Promoter and are not considered by MSA. Accordingly, the application of these Commercial Regulations by the Organisers and/or Championship Promoter will not be subject to the judicial processes of either the Championship Stewards and/or the MSA/MSA.

### 6.1. Championship Contacts

#### 6.1.1. Governing Body

**The Royal Automobile Club Motor Sports Association Limited**, Motor Sports House, Riverside Park, Colnbrook, Slough, SL3 0HG  
Tel: 01753 681736  
Website: [www.msauk.org](http://www.msauk.org)

#### 6.1.2. Administration

#### 6.1.3. Championship Promoter

**Renault UK Ltd**, The Rivers Office Park, Denham Way, Maple Cross, Rickmansworth, Herts, WD3 9YS

##### 6.1.3.1. Championship Manager/Coordinator

**Will Fewkes, Renault UK Ltd**, The Rivers Office Park, Denham Way, Maple Cross, Rickmansworth, Herts, WD3 9YS  
Mobile: 07894 317477  
Email: [w.fewkes-extern@renault.co.uk](mailto:w.fewkes-extern@renault.co.uk)

##### 6.1.3.2. Media Officer

**Carl McKellar**, 5 New Road, Greens Norton, Northants, NN12 8BW  
Tel: 07786 138905  
Email: [c.mckellar-extern@renault.co.uk](mailto:c.mckellar-extern@renault.co.uk)

##### 6.1.4.1. Championship Eligibility/Safety Scrutineer

**Keith Auld**, 53 Orchard Drive, Ackworth, Pontefract, W Yorks, WF7 7DS  
Tel: 01977 611746 Mobile: 07778 268528  
Email: [keith.auld@btinternet.com](mailto:keith.auld@btinternet.com)

##### **Rob Mason....**

Tel:  
Email:

##### 6.1.4.2. Control Tyre Supplier

**Shaun Chetwyn, Protyre Motorsport**, Unit 1, Elswick Road, Fenton Ind. Est, Fenton, Stoke-on-Trent, Staffs, ST4 2SB  
Tel: 01782 411001 Mobile: 07968 307584  
Email: [shaun.chetwyn@protyremotorsport.co.uk](mailto:shaun.chetwyn@protyremotorsport.co.uk)

##### 6.1.4.3. Control Fuel Supplier

**Anthony Webb, WP Racing**, Wessex House, Cadland Rd, Hardley, Hythe, Southampton, SO45 3NY  
Tel: 023 8088 4088  
Email: [sales@wp-racing.co.uk](mailto:sales@wp-racing.co.uk)

##### 6.1.4.4. Decal Supplier

**TBA**  
Tel:  
Email:

##### 6.1.5. Clerk of the Course

**Trevor Williams**  
Tel: 07889647270  
Email: [trevorgwilliams@btinternet.com](mailto:trevorgwilliams@btinternet.com)

##### 6.1.6. Renault Sport Official UK Parts Distributor

**John Millett & Denise Trigg, R.Sport LTD**  
Tel: 07990 520010 (John)  
07733330421 (Denise)  
Email: [r\\_sport\\_uk@hotmail.com](mailto:r_sport_uk@hotmail.com)

### 6.1.7. Organising/Registering Club/Circuit

**British Automobile Racing Club (BARC), Thruxton Circuit**, Andover, Hants, SP11 8PN

Tel: 01264 882200

**Silverstone Circuit**, Towcester, Northamptonshire, NN12 8TN

MotorSport Vision Limited, **Brands Hatch Circuit**, Fawkham, Longfield, Kent, DA3 8NG

Tel: 01474 872331

MotorSport Vision Limited, **Snetterton Circuit**, Norwich, Norfolk, NR16 2JU

Tel: 01953 887303

**Croft Circuit**, Dalton On Tees, North Yorkshire, DL2 2PL

Tel :01325 721815

**Donington Park**, Castle Donington, Derby, DE74 2RP

Tel :01332 810048

**Rockingham International Speedway**, Rockingham, Corby, NN17 5AF

Tel :01536 500500

## 6.2. Penalties

A breach of any of the Commercial Undertakings may result in a fine, up to a maximum of £1,000 for each offence, being imposed by the Championship Manager. Championship registration will be temporarily suspended until such payment has been received. A serious or continual breach of any of the Commercial Undertakings may render the Entrant ineligible for competition, in which case, participation in the Championship by that Entrant will be entirely at the discretion of the Championship Manager.

### 6.2.1. Registration

All Drivers must be registered with an Entrant. An Entrant is defined as a Renault UK Clio Cup Junior race car owner in possession of an MSA Entrants Licence. The Driver's registration is to be wholly owned by the Entrant.

6.2.2. An Entrant may only change the registered Driver after the first Event scheduled in Regulation 1.5.1. Any change thereafter must be notified to the Championship Management in writing and the new Driver and Entrant **must complete and sign** a registration form.

6.2.3. If an Entrant fails to fulfil its entry in an Event, the Championship Manager shall reserve the right to rescind that registration and offer the place to another Entrant.

6.2.4. The Championship Organisers reserve the right to add or vary the Commercial Regulations at their sole discretion.

## 6.3. Passes

6.3.1 Passes are issued on condition that the person or organisation to whom they are issued waives any and all claims it may have now or in the future and releases from all liabilities and agrees not to take any legal action and to always hold harmless, BARC and their employees, agents and representatives and servants, the MSA, the Race Organisers, the Promoters, the Venue Owner, the Championship Manager, any participating team and all employees, agents, servants and contractors thereof for any personal injury, death, damage or loss of any kind that the pass holder may sustain as a result of or in connection with the pass holder's presence within the venue. This indemnity does not apply insofar as injury or death is caused as a result of the negligence of the party seeking an indemnity.

## 6.4. Paddock Regulations

6.4.1. Only small four-wheeled motorised Paddock vehicles which are authorised by the Organisers may be used within the Paddock. These vehicles may only be used during authorised times and when driven by a current full road traffic licence holder for race team related business. Recreational use is strictly prohibited. For the avoidance of doubt all two-wheeled transport is banned from the Paddock. Please note that private cars and vans are not considered as Paddock vehicles. Motorised Paddock vehicles may only be used within the venue during the period from 2 (two) hours prior to the first scheduled track activity until 1 (one) hour after the last track activity on each day of the Meeting, including the Paddock set-up day. There is a total ban on their use outside these times.

6.4.2. There is a speed limit of 10mph in the Paddock at each venue. The only movement of race cars permitted in the Paddock is on the way to the Assembly Area and on the way back from Parc Fermé with a current full road traffic licence holder seated in the Driver's position and in control of the car.

6.4.3. Tailgates on transporters must remain closed at all times except when loading and/or unloading your race cars.

6.4.4. Hard covers should protect any pipes, wires or cables trailing from motorhomes, transporters and/or generators where they will be crossed by pedestrians and/or vehicles.

6.4.5. All health and safety regulations as well as any such directives issued by the Championship and/or the venue

must be met at all times.

**6.4.6.** It is an offence for any person to ride or drive any motor vehicle on the roads or other public areas under the control of the venue promoters unless they are covered by third party insurance. It is a condition of registration that such insurance is in place. A copy of the policy must be lodged with the Championship Manager before the first Event of the season.

**6.4.7.** A fine of a minimum of £500 may be levied for any infringement of Paddock Regulations contained in these Commercial Undertakings at the absolute discretion of the Championship Manager. Each registered Entrant is responsible for the payment of fines incurred by all vehicles entering the Paddock/Pits on their behalf. The decision of the Championship Manager in respect of this additional penalty shall be final with no appeal available.

## **6.5. Timetable Regulations**

**6.5.1.** The Organisers reserve the right to amend the race day timetable at its discretion.

**6.5.2.** Competitors should listen carefully to the Paddock tannoy announcements and their Championship Manager regarding the time they are required in the Assembly Area. In ideal conditions the timetable may be brought forward and Competitors may be called to the Assembly Area earlier than originally scheduled. Competitors are warned that they will miss their qualifying session or race if they are not ready in the Assembly Area when the cars are released.

## **6.6. Radios**

**6.6.1.** Radio frequencies used by a Competitor, team member, manufacturer and/or any of their suppliers must be licensed for use in the UK by the appropriate regional office of the Radiocommunications Agency. The Championship Manager must be notified prior to the start of the season of the Radio Frequency to be used by the Entrant, team members, manufacturers and/or any of their suppliers. A copy of the Licence or Short Term Hire Agreement for the frequency must also be submitted. The Championship Manager reserves the right to request production of the original Licence/Short Term Hire documentation to verify the use of any frequency by an Competitor, team member, manufacturer and/or any of their suppliers at any time during the season.

**6.6.2.** The Competitor, team member, manufacturer and/or any of their suppliers must at all times comply with the terms and conditions specified from time to time by the Radiocommunications Agency for the use of their radio frequency.

**6.6.3.** In the event that a frequency used by an Competitor, team member, manufacturer and/or any of their suppliers interferes with a frequency used by a local emergency service or other third party the Competitor team member, manufacturer and/or supplier shall forthwith change its radio frequency to a non-conflicting frequency to the satisfaction of the Championship Manager and in accordance with the requirements and prior approval of the Radiocommunications Agency. The Competitor, team member, manufacturer and/or any of their suppliers will be suspended from qualifying and racing until a change of frequency has been effected and a copy of the approval of the Radiocommunication Agency submitted to the Championship Manager.

**6.6.4.** If a Competitor, team member, manufacturer and/or any of their suppliers wish to change their frequency they must first obtain approval from the Radiocommunications Agency and submit a copy of such approval to the Championship Manager.

**6.6.5.** It is not permitted to scramble radio speech transmissions or encode them in any way.

## **6.7. Advertising**

**6.7.1.** Advertising of products that are not permitted to be advertised on UK television is forbidden. The Championship Organiser reserves the right to censor any advertising displayed by an Competitor during an Event on its transporter, support vehicles or race car(s) that may be deemed unsuitable.

**6.7.2.** Should any car carry any form of sponsorship or advertising which conflicts in any way with Championship and/or its associate companies or sponsors, the car may not take part in the Championship. The decision of the Championship Organiser is final.

**6.7.3.** A driver must wear their own race suit, carrying the drivers name, BARC and championship badges as stipulated by **Appendix A**, which meets current MSA standards (**Section K9** of the current MSA Yearbook) during race meetings. The position of the championship badges affixed to the driver's race suit must not be altered in any way or be obscured. There is an exclusion zone of 30mm around each championship badge. The race suit must not carry any form of sponsorship or advertising which conflicts in any way with Renault, Michelin or any other championship sponsors or partners. The decision of the Championship Organiser is final. Failure to comply will result in a fine of £100 for the first offence and may increase if the suit is not rectified.

**6.7.4.** All cars must carry the Driver's name in accordance with Regulation **Appendix B**.

**6.7.5.** All surfaces that have not been claimed for decals by Championship, its sponsor companies or used for the application of starting numbers are free for use. The Championship Organiser must approve conflicting sponsors' decals in advance and the position, size and colours (if approved) will be at the discretion of the Championship Organiser. All reserved areas must be adhered to. See **Appendix B**.

**6.7.6.** In order to qualify for points, prize money and bonus awards, Competitors must (provided that these items are available at an Event):

(i) carry the correct Championship decals on their cars in the positions indicated. See **Appendix B**.

(ii) wear a race suit which meets current MSA standards with appropriate Championship badges, if provided, unless exemption from this clause has been obtained in writing from the Championship Organiser.

#### **6.7.7. Decal penalties**

All cars must carry the mandatory Championship decals during qualifying sessions and races. See **Appendix B**. Failure to comply with this Regulation will result in a penalty of:

- (i) £100 for the first infringement,
- (ii) £500 for every subsequent infringement.

### **6.8 Testing**

#### **6.8.1 General**

During Championship official test days and free practice sessions all cars must comply with the current Championship Technical Regulations. In the event of a car being deemed ineligible by the Championship Eligibility/Safety Scrutineer it will not be permitted to take part in that session and the Competitor concerned may be called before the Championship Stewards. Furthermore the Driver's times will be deleted from the relevant session.

**6.8.1.1** If a Driver causes a stoppage during the course of any Championship official test day then his/her continued participation shall be at the discretion of the Championship Manager or their appointed representative.

#### **6.8.2. Restrictions**

Restrictions on testing involving a Renault UK Clio Cup Junior race car, defined as any Renault UK Clio Cup Junior racing car version in any specification apply during the current season commencing midnight on

**Sunday, 18<sup>th</sup> March, 2018**

The Championship Manager reserves the right to clarify or amend the restrictions at any time in their absolute discretion, in which case they will notify registered Competitors by way of a Championship Bulletin to be issued by hand or sent by post or electronic mail to the address supplied on the registration form.

**6.8.2.1.** A registered Driver may only take part in test sessions as follows:

- i) Championship official test days and/or tests the day prior to Championship Events.
- ii) May not take part in a track/test/race at a circuit or any part of a circuit within 28 days of a championship event

**6.8.2.2.** The Championship Manager may set any additional restrictions upon a competitor whose registration is accepted beyond the deadline for registrations (see regulation 1.4.1), as is seen fit which may involve; excluding participation in Official test days.

**6.8.2.3.** Drivers wishing to register and compete at any event, at any time, during the current Renault UK Clio Cup Junior Championship season will only be permitted to do so providing they have not taken part in a Race/Test or Track day within 28 days prior to the event in which they wish to participate.

#### **6.8.3. Championship Test Days**

A list of official Championship test days will be nominated and circulated in a Championship Newsletter prior to the first Event. The Championship Organisers reserve the right to alter or amend the list of Championship official test days and will inform all registered Competitors of such a change by an official Championship Newsletter.

#### **6.8.4 Sanction**

Failure to comply with the any of the provisions of Regulation 6.8 may result in a fine of up to £50,000 and/or exclusion from all or part of the current Renault UK Clio Cup Junior being imposed.

### **6.9. Publicity**

**6.9.1.** It is incumbent upon all persons connected with the current Renault UK Clio Cup Junior to promote the highest ideals of the Championship at all times. No person connected with the Championship shall bring it into disrepute by means of a statement, communication or press release given to journalists or other members of the media (both audio, visual, print and online), which may be considered negative or demeaning. Drivers may not publish press releases or make statements or comments that refer to the Championship or their fellow Drivers in a derogatory way.

**6.9.2.** All Drivers who are required for the podium presentations in accordance with Regulation 3.13.3. shall attend the podium ceremony and conduct all post-race interviews wearing their official Championship podium cap, which will be provided by the Championship Manager.

**6.9.3.** Drivers must take part in any autograph session or press interview wearing their official Championship podium cap should this be required by the Championship Manager.

**6.9.4.** In signing the Championship Registration form, Competitors agree that the Championship (and those authorised by it) and sponsors of the current Championship may make use of his/her/its activities and successes in motorsport for any advertising, publicity, public relations and merchandising purposes. Competitors also agree that in any advertising or promotion with which he/she/it is associated (relating to the Championship) the full title of the Championship (including the Championship sponsors name and the Championship logo) will be used at all times.

## **6.10. Television**

- 6.10.1.** By entering the Championship, Competitors and their teams are obliged to assist the Championship in the promotion of the Championship and, in particular, the television coverage. All Competitors are obliged to assist the Championship nominated TV production company in the filming of the Championship by granting interviews when requested and any other reasonable request of the TV production company or Championship Manager. All television interviews shall be conducted while wearing an appropriate race suit or team clothing and an official Championship podium cap, at the request of the Championship Manager.
- 6.10.2.** At the sole discretion of the Championship Manager cars must carry an in-car or on-board camera and allow this equipment to be fitted at any time at the reasonable request of the TV production company.
- 6.10.3.** Competitors selected to carry an in-car or on-board camera may be required to display a Championship title logo in front of the camera. No other advertising will be permitted in the cockpit, or in front of the camera.
- 6.10.4.** Any Competitor and/or anyone connected with an Competitor is forbidden from trying to influence the editorial decisions of the TV production company in connection with the Championship as it is shown on television.
- 6.10.5.** All broadcast, recording, cable, satellite, digital, video, internet and interactive rights and other rights in all media and other related events are the property of Renault UK. Any recording or broadcast of the Championship and other related events, or rebroadcast or reproduction of material without express written permission of the Championship Organiser is strictly forbidden. Competitors currently registered in the Championship may, subject to the prior written permission of the Championship Organiser and subject to any conditions that he may impose at his absolute discretion, be granted rights to use broadcast material for their own specific promotional use within the UK. Rights requested for any other commercial use must be made in writing to the Championship Organiser and if granted will be subject to Licence, which may include a fee or charge.
- 6.10.6.** All independent filming and any filming outside of the provisions of 6.10.1 to 6.10.5 above is strictly forbidden. Any exceptions should be applied for in advance to the Championship Manager. Any on-board footage containing vision or sound of anything out of the ordinary, negative or untoward - particularly regarding another competitor - cannot be used (e.g. another car spinning off, or having an incident or mechanical failure etc).

## **6.11. Championship Cameras**

- 6.11.1.** Only in-car or on-board cameras supplied by the Championship may be used. Once fitted, the cameras must not be tampered with. The in-car or on-board camera remains the property of the Championship and may be required to be returned at the end of the Event. Competitors will be charged for repair or replacement of the cameras due to accident damage, misuse or loss at any time during the Event.
- 6.11.2.** The onus is on the competitor to ensure that the Championship camera is switched on and recording for all races. This must be done before the two-minute race start signal.
- 6.11.3.** Details of the specification, installation and operating procedures for the Championship camera will be made available to all competitors via a Newsletter. No other in-car or on-board camera, still or motion picture camera will be permitted.
- 6.11.4.** No advertising will be permitted in the cockpit, or in front of the camera.
- 6.11.5.** Any action by an Competitor to render any in-car or on-board camera inoperable for broadcast will result in a fine of £500 for each and every offence at the discretion of the Championship Organiser.
- 6.11.6.** Any Competitor who does not return the camera, SD card, clamp and other accessories in working order to the Championship Manager at the end of the season or when a registration is withdrawn, will be charged £1,500 for replacement of goods.

## **6.12. Miscellaneous**

- 6.12.1.** At the start of each Event, qualifying session or race, each car must be clean and in a correct state of repair to represent Renault UK's best interests. The Clerk of the Course, in conjunction with the Championship Eligibility/Safety Scrutineer and the Championship Manager, reserves the right to exclude cars not meeting this requirement from taking part.

Appendix A

Suit Decal Plan - TBC

**CLIO CUP**

RENAULT UK

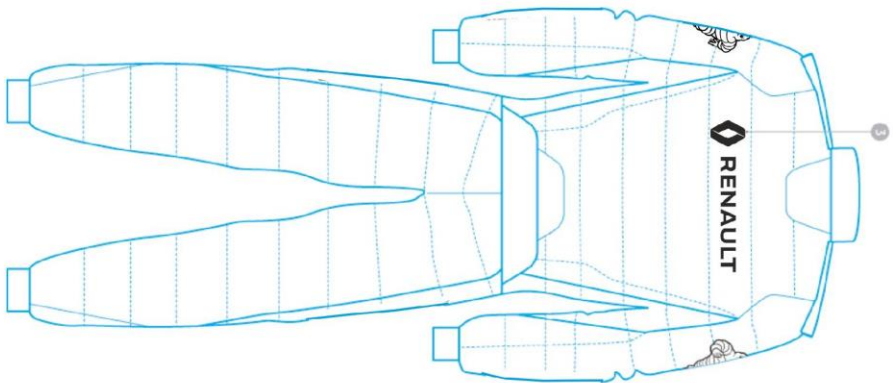
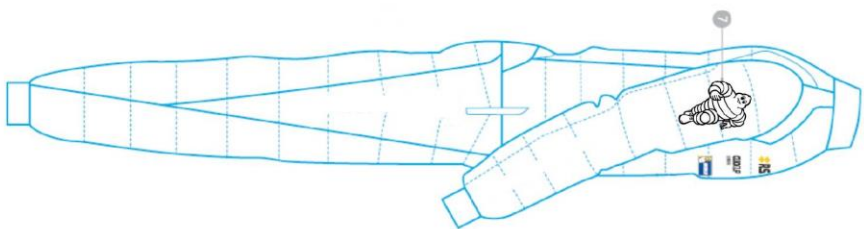
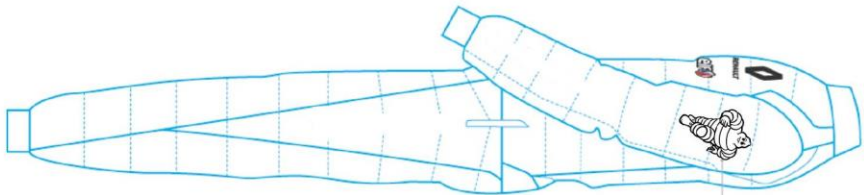
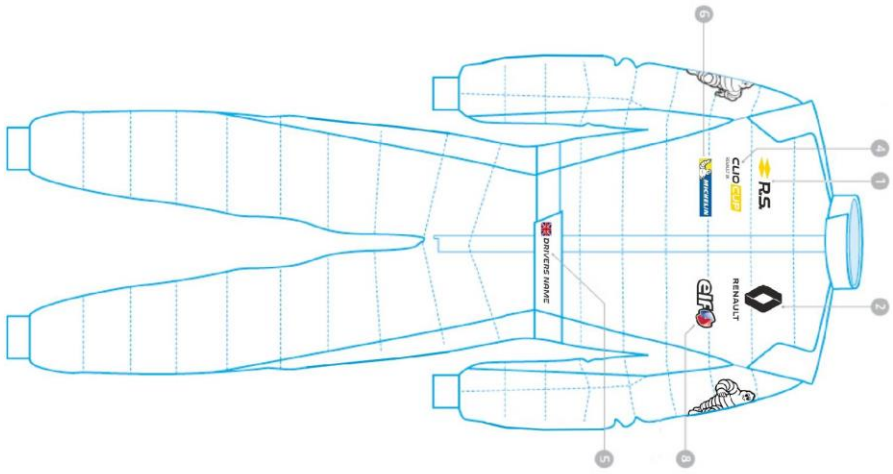

**RENAULT**

© Renault – February 2017 - For information only. Do not use as production file.

26.02.2017

- 1 R5 signature, front / back: Length: 9cm
- 2 Renault vertical logo type: Height: 8cm
- 3 Renault High visibility logo type, front / back: Length: 26cm
- 4 Clio Cup Nation: Length: 9cm
- 5 Flag + pilot's first name: Renault Race font
- 6 Michelin logo type: Length: 10cm

- 7 Bbandum Sprinter: Height: 11.5cm
- 8 Eif logo type: Length: 5.5cm



GOSPORTS LTD  
 02017 6000000 - ALL RIGHTS RESERVED  
 TEL: +44 (0)1753 51111 Email: info@gosports.co.uk

# Appendix B

## Car Decal Plan - TBC



RENAULT UK



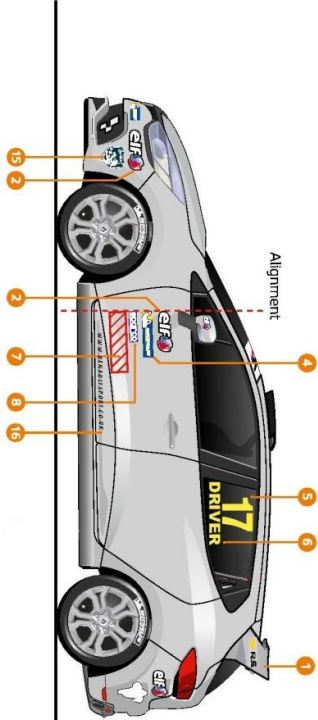

Alignment

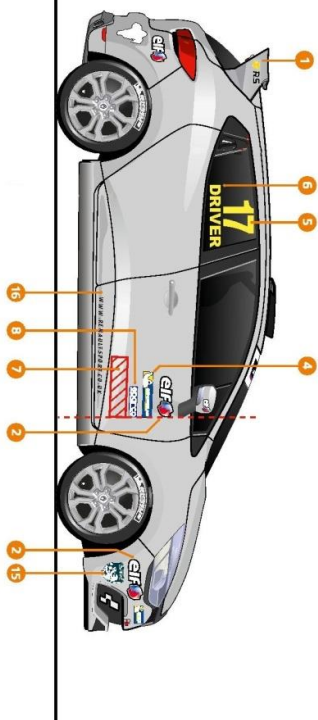

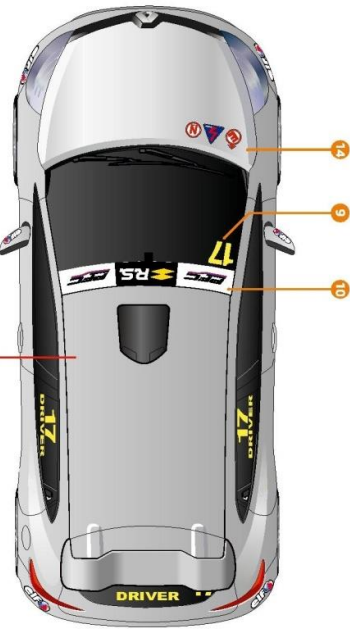

Free body color

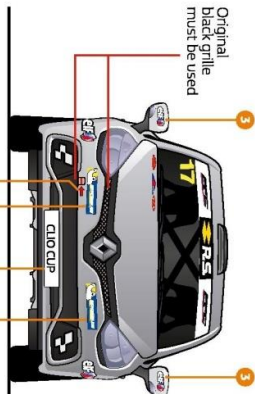

Original black grille must be used

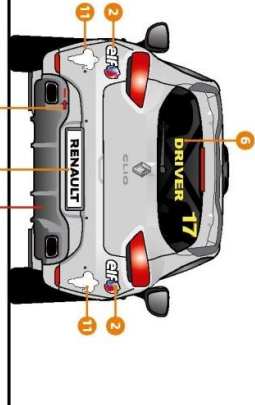

Original colour Not to be painted

- 1 R.S. Signature
- 2 ELF + Tripan ( 200mm Long )
- 3 ELF + Tripan ( Mirrors ) : 100mm Long
- 4 MICHELIN : 300mm Long
- 5 NUMBERS ( Side Windows ) : 200mm high ( Fluoro Yellow )
- 6 Drivers Name : 80mm high ( Fluoro Yellow )
- 7 Area Reserved for RENAULT SPORT Partners
- 8 SPARCO : 20mm Long
- 9 Numbers ( Front & Rear Screens ) : 150mm high ( Fluoro Yellow )
- 10 Screen Header ( PFC / RS / PFC )
- 11 Bihendum Sprinter : 200mm high
- 12 CLIO CUP : ( Front Number Plate )
- 13 RENAULT : Rear Number Plate
- 14 Technical Stickers
- 15 BARC Shield : ( Front Bumpers )
- 16 www.RENAULTSPORT.co.uk : ( Lower Doors ) 640mm long



©Renault UK - 05.03.17 - For information only - Do not use as production file



## Appendix C:

### Race 'n' Respect

#### THE RACING CODE

##### Volunteer Officials' & Organisers Commitments:

###### *I will:*

Recognise that there are different groups within the racing family and treat them appropriately

Create a welcoming, friendly and safe environment for everyone

Treat every competitor fairly and encourage others to do so

Recognise that as a representative of the sport, I have a duty to be polite and treat racers, volunteers and supporters with respect

##### Parents & Guardians Commitments:

###### *I will:*

Encourage my young driver to have fun and enjoy racing

Not put pressure on my young driver to take part

Not impose my own ambitions on my young driver

Not expect my young driver to win and recognise that the benefits of junior racing lie in the skill acquisition and not about winning events and championships

Not criticise my young driver when they make mistakes

Never encourage my young driver to break or bend the rules

Respect other competitors and their families and applaud their success

Respect the decisions of the officials at all times

Parent's & Guardian's Commitments

##### COMPETITORS' Commitments:

###### *I will:*

Race for enjoyment

Try my best at all times

Race fairly

Be polite and treat everyone with respect

Not show off if I win

Not get upset if I don't win

##### Teams' Commitments:

###### *We:*

Accept that racing is primarily about enjoyment

Will not put pressure on young racers to achieve results

Will recognise that junior racing is about skill acquisition, not about winning events and championships

Will never speak or behave inappropriately.

Will encourage all racers to respect the rules and the authority of the officials

Will never encourage a racer to break or bend the rules, nor to drive in a manner that could cause injury to themselves or others

Recognise this is not Formula 1

[www.msauk.org/respect](http://www.msauk.org/respect)